

## CHAPTER

## 9

## Filter Circuits

## 9.1 INTRODUCTION

Passive filters are built from passive components; resistors, capacitors, and inductors. **Active filters** also use resistors and capacitors, but the inductors are replaced by active devices capable of producing power gain. These devices can range from single transistor to integrated circuit (IC)—controlled sources such as the operational amplifier (op amp), and more exotic devices, such as the operational transconductance amplifier (OTA), the generalized impedance converter (GIC), and the frequency-dependent negative resistor (FDNR).

In this chapter, active filters with op-amp have been discussed.

## 9.1.1 Operational Amplifier (Op-Amp)

An operational amplifier is a direct-coupled high gain, differential-input amplifier.

With the addition of suitable external feedback components, an op-amp can be used for a variety of application, such as ac and dc signal amplification, active filters, oscillators, comparators, regulators, and others.

## 9.1.2 Operational Amplifier Terminals

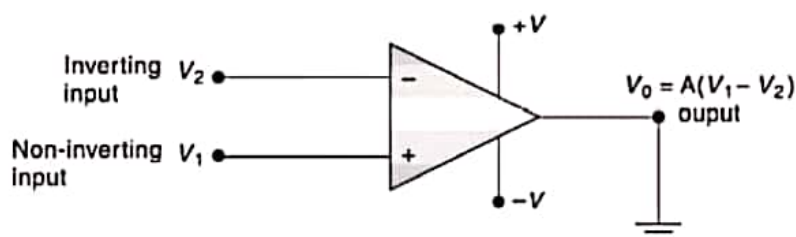

Figure 9.1 Operational amplifier

Op-amp has five basic terminals—

- (i) Two for input signals,  $V_1$  and  $V_2$  – differential input terminals.
- (ii) One for output signal,  $V_0$  single-ended output.
- (iii) Two for power supply,  $+V$  and  $-V$ . (Maximum  $V = \pm 18$  V)

**Note** The power supply has three terminals: positive, negative and power supply common. The common terminal may or may not be wired to earth ground via the third wire of line cord. However, it has become standard practice to show power common as a ground symbol.

Use of the term 'ground' on the ground symbol is a convention which indicates that all voltage measurements are with respect to 'ground'.

### 9.1.3 Op-Amp Characteristics

#### **Ideal Characteristics**

- (i) An infinite voltage gain
- (ii) An infinite bandwidth
- (iii) An infinite input impedance
- (iv) Zero output impedance
- (v) Perfect balance, i.e., the output is zero when equal voltages are present at the two input terminals; and
- (vi) The characteristics do not change with temperature

#### **Practical (Actual) Characteristics**

- (i) The gain at low- frequency is finite and very high (of the order of  $10^3$  to  $10^6$ ). The gain is constant upto a few hundred kHz and then decreases monotonically with the increase in frequency.
- (ii) The bandwidth is finite and very high.
- (iii) The input impedance lies in the range of  $150$  k $\Omega$  to a few hundred M  $\Omega$ .
- (iv) The output impedance of a practical op-amp lies between  $0.75$  to  $100$   $\Omega$ .
- (v) Perfect balance is not achieved with practical op-amps.

## 9.2 FILTER

An electric filter is a four-terminal frequency-selective network designed generally with reactive elements to transmit freely a specified band of frequency and block or attenuate signals of frequency outside this band.

- The band of frequency transmitted through the filter is called the Pass-band.
- The band of frequency which is severely attenuated by the filter is called the attenuated or stop-band.

## 9.3 CLASSIFICATION OF FILTERS

This must be remembered that there is no simple hierarchical classification of filters. Filters may be classified on different bases which overlap each other in many respects.

Depending upon the type of techniques used in signal processing, filters are classified as:

- (i) Analog Filters, and
- (ii) Digital Filters.

Analog filters are designed to process analog signals using analog techniques, while digital filters process analog signals using digital techniques.

Depending on the type of elements used in their construction, filters are classified as:

- (i) Active Filters, and
- (ii) Passive Filters.

A passive filter is built with passive components such as resistors, capacitors and inductors. Active filters, on the other hand, make use of transistors or op-amps (providing voltage amplification, and signal isolation or buffering) in addition to resistors and capacitors.

Depending upon the type of elements used, the operating frequency range of the filter will be different and accordingly the filters are classified as:

- (i) Low Pass Filters,
- (ii) High Pass Filters,
- (iii) Bands Pass Filters,
- (iv) Band Stop Filters, and
- (v) All Pass Filters.

**1. Low-Pass Filter** It is a circuit that has a constant output (or gain) from zero to a cut-off frequency,  $f_c$  and attenuation of all frequencies above  $f_c$ .

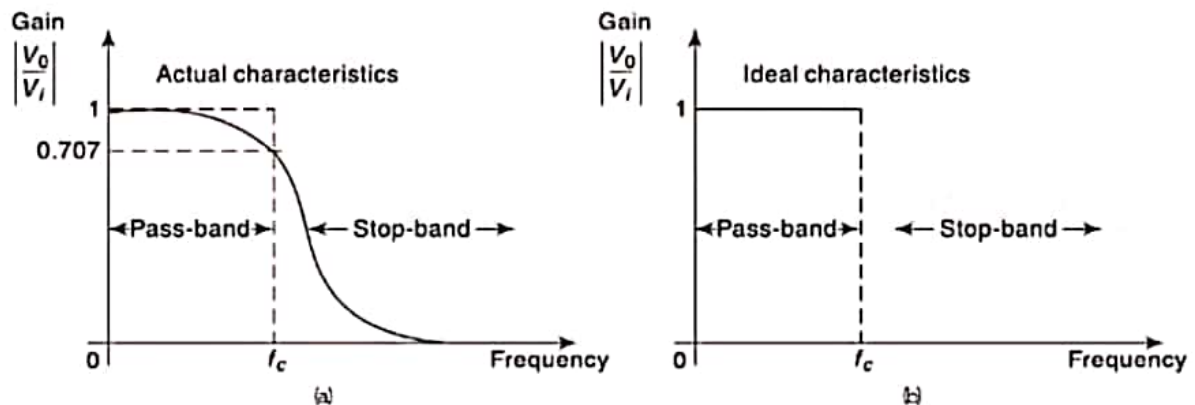

Figure 9.2 Low-pass filter characteristics: (a) Actual (b) Ideal

**2. High-Pass Filter** It is a circuit that attenuates all signals of frequency below the cut-off frequency and has a constant output (or gain) above this frequency.

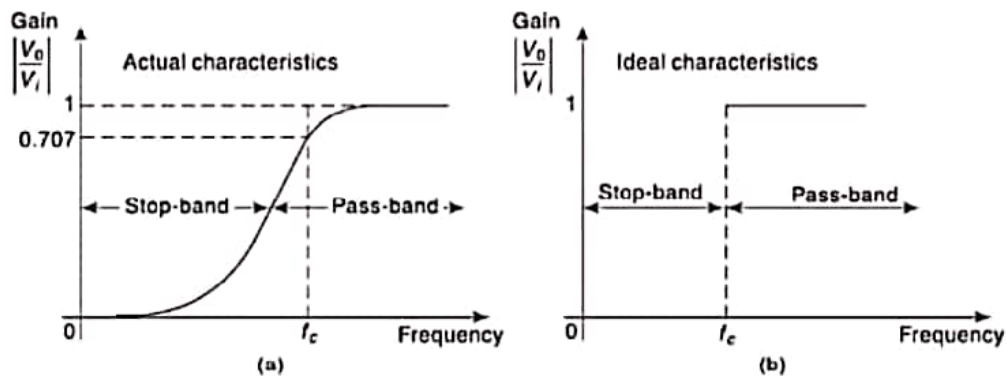

Figure 9.3 High pass filter characteristics (a) Actual (b) Ideal

**3. Band-Pass Filter** It is a circuit that passes a band of frequencies and attenuates all frequencies outside the band.

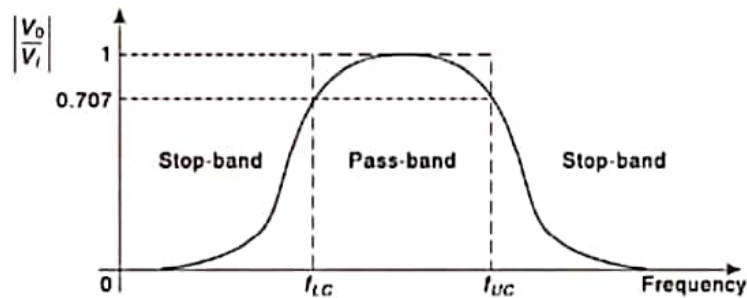

Figure 9.4 Band pass filter characteristics

**4. Band-Rejection/Elimination Filter or Band Stop Filter or Notch Filter** It rejects a specified Band of frequencies while passing all other frequencies outside the band.

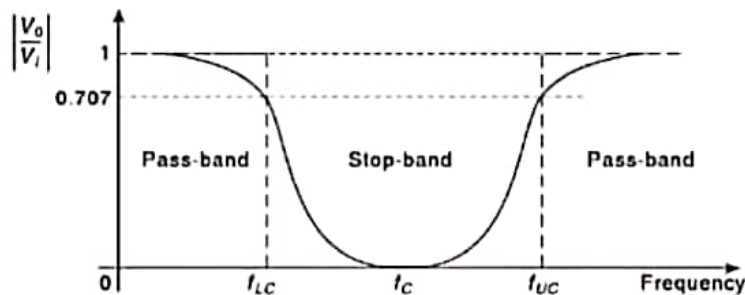

Figure 9.5 Band reject filter characteristics

**5. All-Pass Filter** It passes all frequencies equally well, i.e., output and input voltages are equal in magnitude for all frequency; with the phase-shift between the two a function of frequency.

This filter is also known as a **phase-shift filter**, **time-delay filter**, or simply the **delay equalizer**. One major application of an all-pass filter is the simulation of a lossless transmission line. The magnitude of the output voltage is the same as the input voltage but the output voltage is shifted in phase with respect to the input voltage.

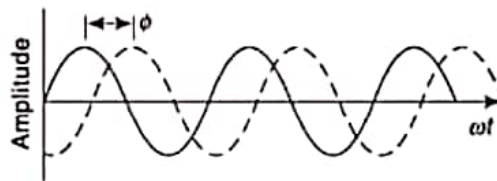

Figure 9.6 All pass filters characteristics

The highest frequency up to which the input and output amplitudes remain equal is dependent on the unity-gain bandwidth of the op-amp. At this frequency, however, the phase-shift between the input and output is maximum.

## 9.4 ADVANTAGES OF ACTIVE FILTERS OVER PASSIVE FILTERS

1. **Less Cost** Active filters are very much inexpensive than passive filters due to the variety of cheaper op-amp and the absence of costly inductors.
2. **Gain and Frequency Adjustment Flexibility** Since the op-amp is capable of providing a gain (which may also be variable), the input signal is not attenuated as it is in a passive filter. In addition, the active filter is easier to tune or adjust.
3. **No Loading Problem** Active filters provide an excellent isolation between the individual stages due to the high input impedance (ranging from a few  $k\Omega$  to a several thousand  $M\Omega$ ) and low output impedance (ranging from less than  $1\ \Omega$  to a few hundred  $\Omega$ ). So, the active filter does not cause loading of the source or load.
4. **Size and Weight** Active filters are small in size and less bulky (due to the absence of bulky 'L') and are rugged.
5. **Non-floating Input and Output** Active filters generally have single ended inputs and outputs which do not 'float' with respect to the system power supply or common. This property is different from that of the passive filters.

## 9.5 APPLICATION OF ACTIVE FILTERS

Application of active filters is given below. They are used

- (i) in the field of communication and signal processing
- (ii) in almost all sophisticated electronic systems, such as radio, television, telephone, radar, space satellites, biomedical equipments, and so on.

## 9.6 LOW-PASS ACTIVE FILTER

The circuit of Figure 9.7 is a commonly used low-pass active filter.

The filtering is done by the  $RC$  network, and the op-amp is used as a unity-gain amplifier. The resistor  $R_f (= R)$  is included for DC offset.

[At DC, the capacitive reactance is infinite and the dc resistive path to ground for both terminals should be equal.]

Here, all the voltages  $V_i$ ,  $V_{i'}$ ,  $V_o$  are measured with respect to ground.

Since the input impedance of the op-amp is infinite, no current will flow into the input terminals.

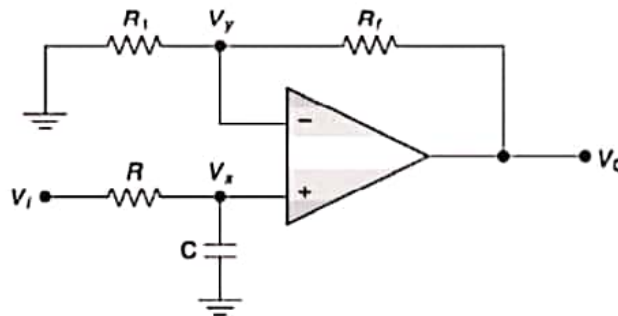

Figure 9.7 First order low-pass active filter circuit

$$V_y = \frac{V_0}{R_1 + R_f} \times R_1 \quad (9.1)$$

According to the voltage divider – rule, the voltage across the capacitor,

$$\begin{aligned} V_x &= \frac{X_c}{R + X_c} V_i; \quad X_c = \frac{1}{j\omega C} = \frac{1}{j2\pi fC} \\ &= \frac{1/j2\pi fC}{R + \frac{1}{j2\pi fC}} V_i \\ &= \frac{V_i}{1 + j2\pi fRC} \end{aligned} \quad (9.2)$$

Since the op-amp gain is infinite,

$$\begin{aligned} \therefore \quad V_x &= V_y \\ \text{or,} \quad \frac{V_0 R_1}{R_1 + R_f} &= \frac{V_i}{1 + j2\pi fRC} \end{aligned}$$

$$\Rightarrow \frac{V_0}{V_i} = \frac{(1 + R_f/R_1)}{1 + j2\pi fRC}$$

$$\text{or,} \quad \boxed{\frac{V_0}{V_i} = \frac{A_F}{1 + j(f/f_c)} = A_{cL}}$$

where,  $A_F = \left(1 + \frac{R_f}{R_1}\right)$  = pass-band gain of the filter.

$f$  = frequency of the input signal.

$f_c = \frac{1}{2\pi RC}$  = cut-off frequency of the filter.

$A_{cL}$  = Closed- loop gain of the filter as a function of frequency.

The gain magnitude,

$$|A_{cL}| = \left| \frac{V_0}{V_i} \right| = \frac{A_F}{\sqrt{1 + (f/f_c)^2}} = \frac{A_F}{\sqrt{1 + \omega^2 R^2 C^2}}$$

and phase angle (in degree),

$$\phi = -\tan^{-1}\left(\frac{f}{f_c}\right) = -\tan^{-1}(\omega RC)$$

### 9.6.1 Operation of the Filter

The operation of the low-pass filter can be verified from the gain magnitude equation as follows:

1. At very low frequencies, i.e.,  $f \ll f_c$ ,

$$|A_{CL}| \cong A_F$$

2. At  $f = f_c$ ,  $|A_{CL}| = \frac{A_F}{\sqrt{2}} = 0.707 A_F = -3\text{dB } A_F$ ,  $\phi = -45^\circ$

3. At  $f > f_c$ ,  $|A_{CL}| < A_F$

Thus, the filter has a constant gain of  $A_F$  from 0 Hz to the cut-off frequency  $f_c$ . At  $f_c$ , the gain is  $0.707A_F$  and after  $f_c$ , it decreases at a constant rate with an increase in frequency.

Figure 9.8 shows that the actual response deviates from the straight dashed-line approximation at the vicinity of ' $f_c$ '.

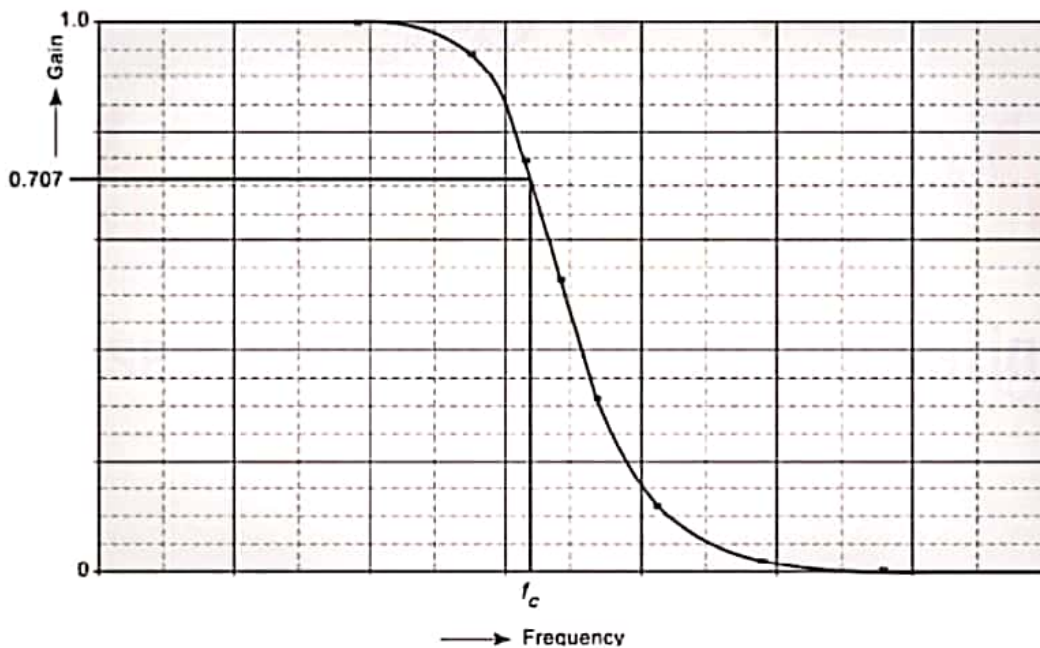

**Figure 9.8** Low pass filter characteristics

At  $\omega = 0.1 \omega_c$ ,  $|A_{CL}| \cong 1(0 \text{ dB})$

At  $\omega = 10 \omega_c$ ,  $|A_{CL}| \cong 0.1(-20 \text{ dB})$

The table below gives the magnitude and phase angle for different values of  $\omega$  between  $0.1\omega_c$  and  $10\omega_c$ .

$\omega$	$A_{cl}$	Phase-angle (degree)
$0.1\omega_c$	1.0	-6
$0.25\omega_c$	0.97	-14
$0.5\omega_c$	0.89	-27
$\omega_c$	0.707	-45
$2\omega_c$	0.445	-63
$4\omega_c$	0.25	-76
$10\omega_c$	0.1	-84

### 9.6.2 Filter Design

A low-pass active filter can be designed by implementing the following steps:-

1. A value of the cut-off frequency  $\omega_c$  (or,  $f_c$ ) is chosen.
2. A value of the capacitance  $C$  is selected; usually the value is between 0.001 and 0.1  $\mu\text{F}$ . Mylar or tantalum capacitors are recommended for better performance.
3. The value of the resistance  $R$  is calculated from the relation,

$$R(\text{in } \Omega) = \frac{1}{\omega_c C} = \frac{1}{2\pi f_c C}$$

$f_c$  = cut-off frequency in hertz

$\omega_c$  = cut-off frequency radian/second

$C$  = in farad

4. Finally, the values of  $R_1$  and  $R_f$  are selected depending on the desired pass band gain by using the relation  $A_F = \left(1 + \frac{R_f}{R_1}\right)$ .

### 9.6.3 Frequency Scaling

Once a filter is designed, there may be a need to change its cut-off frequency. The procedure used to convert an original cut-off frequency  $f_c$  to a new cut-off frequency  $f'_c$  is called 'frequency-scaling'.

It is accomplished as follows:-

To change a cut-off frequency, multiply  $R$  or  $C$ , but not both by the ratio

$$\left( \frac{\text{Old Cut-off Frequency, } f_{c\text{old}}}{\text{New Cut-off Frequency, } f_{c\text{new}}} \right)$$

#### Example 9.1

- (a) Design a low-pass active filter at a cut-off frequency of 1 kHz with a pass band gain of 2. Using the frequency scaling technique, convert this filter to a low-pass filter of cut-off frequency 1.6 kHz.
- (b) Plot the frequency response of this low-pass active filter.

**Solution**

- (a) Here,  $f_c = 1$  kHz,  $A_F = 2$ ; Let,  $C = 0.01$   $\mu\text{F}$ .

$$R = \frac{1}{2\pi f_c C} = \frac{1}{2\pi \times 10^3 \times 0.01 \times 10^{-6}} = 15.9 \text{ k}\Omega$$

$$\therefore A_F = 2 = \left(1 + \frac{R_f}{R_1}\right) \Rightarrow R_f = R_1 = 10 \text{ k}\Omega$$



So, the complete circuit is shown in Fig. 9.9(a).

To change the cut-off frequency from 1 kHz to 1.6 kHz, we multiply the 15.9 k $\Omega$  resistor by

$$\frac{\text{Original Cut-off frequency}}{\text{New Cut-off frequency}} = \frac{1}{1.6} = 0.625$$

$$\therefore \text{New resistor, } R = 15.9 \times 0.625 = 9.94 \text{ k}\Omega$$

(b) To plot the frequency-response, the data are obtained from the equation,

$$\left| \frac{V_0}{V_{in}} \right| = \frac{A_F}{\sqrt{1 + (f/f_c)^2}}$$

Frequency (Hz)	Gain	Gain (in dB)
10	2	6.02
100	1.99	5.98
200	1.96	5.85
700	1.64	4.29
1,000	1.41	3.01
3,000	0.63	-3.98
7,000	0.28	-10.97
10,000	0.20	-14.02
30,000	0.07	-23.53
100,000	0.02	-33.98

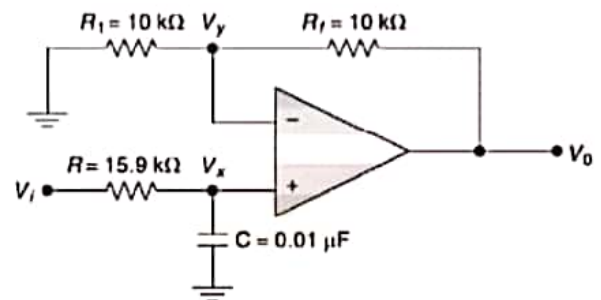

Figure 9.9(a) Circuit of Example 9.1

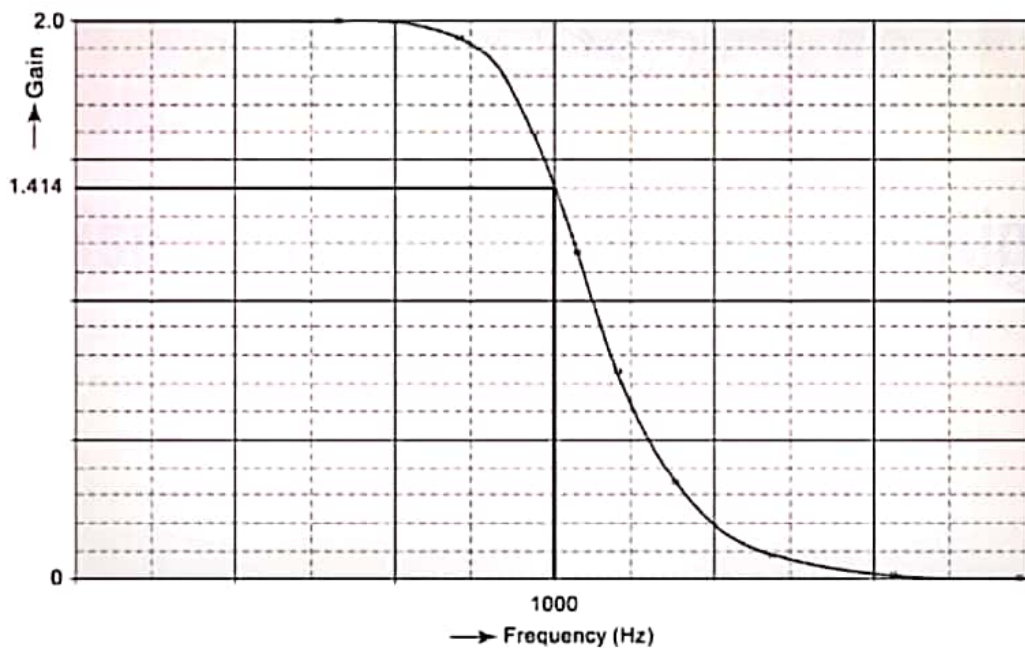

Figure 9.9(b) Filter characteristics of Example 9.1

## 9.7 HIGH-PASS ACTIVE FILTER

The circuit is shown in Fig. 9.10.

The filtering is done by the CR network and the op-amp is connected as a unity – gain follower. The feedback resistor,  $R_f$  is included to minimize dc off-set.

Here,

$$V_y = V_0 \frac{R_1}{R_1 + R_f} \quad (9.3)$$

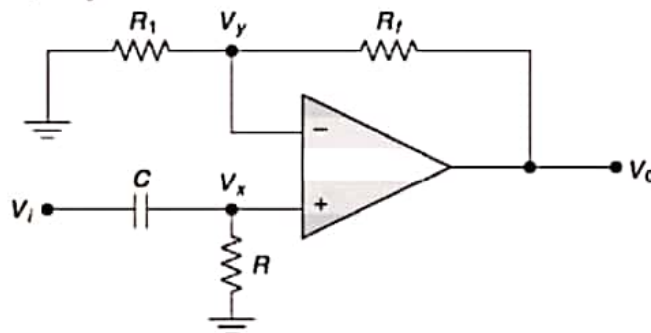

Figure 9.10 First order high pass active filter circuit

Voltage across the resistor  $R$ ,

$$V_x = \frac{R}{R + X_c} V_i = \frac{R}{R + \frac{1}{j\omega C}} V_i = \frac{j\omega RC}{1 + j\omega RC} V_i \quad (9.4)$$

Since op-amp gain is infinite,

$$V_x = V_y$$

$$\Rightarrow \frac{V_0 R_1}{R_f + R_1} = \frac{j\omega RC}{1 + j\omega RC} V_i$$

$$\Rightarrow \frac{V_0}{V_i} = \left( \frac{R_f + R_1}{R_1} \right) \left( \frac{j\omega RC}{1 + j\omega RC} \right) = A_F \times \frac{j2\pi f RC}{1 + j2\pi f RC}$$

$$\boxed{\frac{V_0}{V_i} = A_F \left[ \frac{j(f/f_c)}{1 + j(f/f_c)} \right]}$$

where,  $A_F = (1 + R_f/R_1)$  = Pass-band Gain of the filter,

$f$  = frequency of the input signal (Hz),

$f_c = \frac{1}{2\pi RC}$  cut-off frequency of the filter (Hz).

The gain- magnitude,

$$\left| \frac{V_0}{V_i} \right| = \frac{A_F (f/f_c)}{\sqrt{1 + (f/f_c)^2}} = A_F \cdot \frac{\omega RC}{\sqrt{1 + \omega^2 R^2 C^2}}$$

and phase-angle (in degree),  $\phi = 90^\circ - \tan^{-1} (f/f_c) = 90^\circ - \tan^{-1} (\omega RC)$

### 9.7.1 Operation of the Filter

The operation of the high-pass filter can be verified from the gain-magnitude equation as follows:

1. At very low frequencies, i.e.,  $f < f_c$ ,  $\left| \frac{V_0}{V_i} \right| < A_F$

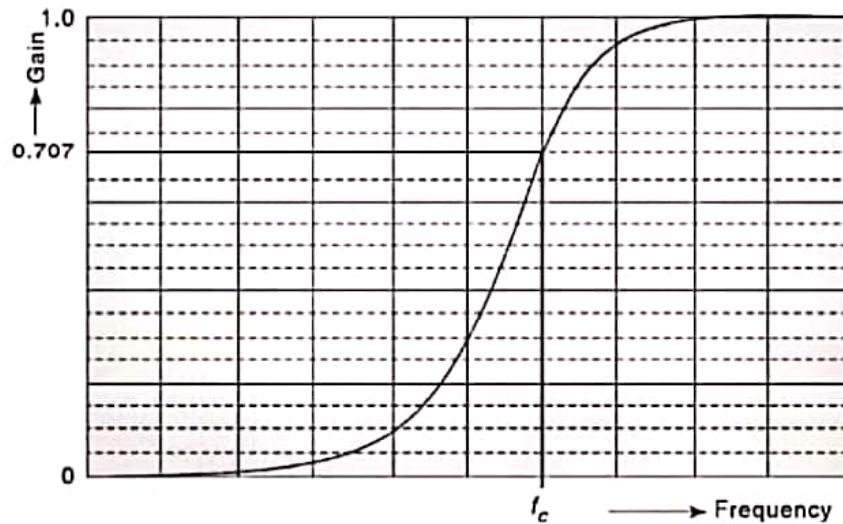

Figure 9.11 High pass filter characteristics

2. At  $f = f_c$ ,  $\left| \frac{V_0}{V_i} \right| = \frac{A_F}{\sqrt{2}} = 0.707 A_F = -3 \text{ dB}$ ,  $\phi = 45^\circ$
3. At  $f \gg f_c$ ,  $\left| \frac{V_0}{V_i} \right| \cong A_F$

### 9.7.2 Filter Design

A high-pass active filter can be designed by implementing the following steps:

1. A value of the cut-off frequency,  $\omega_c$  (or  $f_c$ ) is chosen.
2. A value of the capacitance  $C$ , usually between 0.001 and 0.1  $\mu\text{F}$ , is selected.
3. The value of the resistance  $R$  is calculated using the relation,

$$R = \frac{1}{\omega_c C} = \frac{1}{2\pi f_c C}$$

4. Finally, the values of  $R_1$  and  $R_f$  are selected depending on the desired pass-band gain, using,

$$\text{the relation, } A_F = \left( 1 + \frac{R_f}{R_1} \right).$$

#### Example 9.2

- (a) Design a high-pass active filter of cut-off frequency 1 kHz with a pass-band gain of 2.
- (b) Plot the frequency response of the filter.

9.12

Circuit Theory and Networks

**Solution**(a) Here,  $f_c = 1\text{ kHz}$ ,  $A_F = 2$ Let,  $C = 0.01\ \mu\text{F}$ .

$$\therefore R = \frac{1}{2\pi f_c C} = \frac{1}{2\pi \times 10^3 \times 0.01 \times 10^{-6}} = 15.9\ \text{k}\Omega$$

$$\therefore A_F = 2 = \left(1 + \frac{R_f}{R_1}\right) \Rightarrow R_f = R_1 = 10\ \text{k}\Omega$$

So, the complete circuit is shown in Fig. 9.12(a).

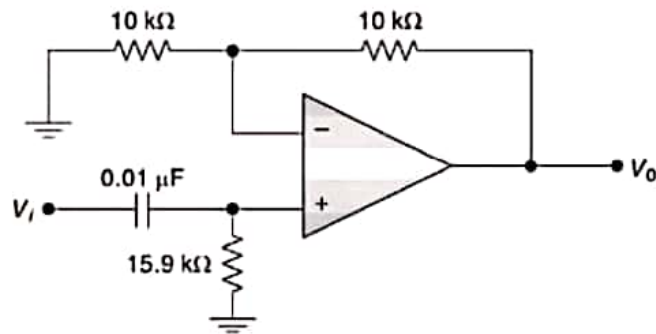
**Figure 9.12(a)** Circuit of Example (9.2)(b) The data for the frequency response plot can be obtained by substituting the input frequency ( $f$ ) values from 100 Hz to 100 kHz in the equation.

$$\frac{V_o}{V_i} = \frac{A_F(f/f_c)}{\sqrt{1 + (f/f_c)^2}}$$

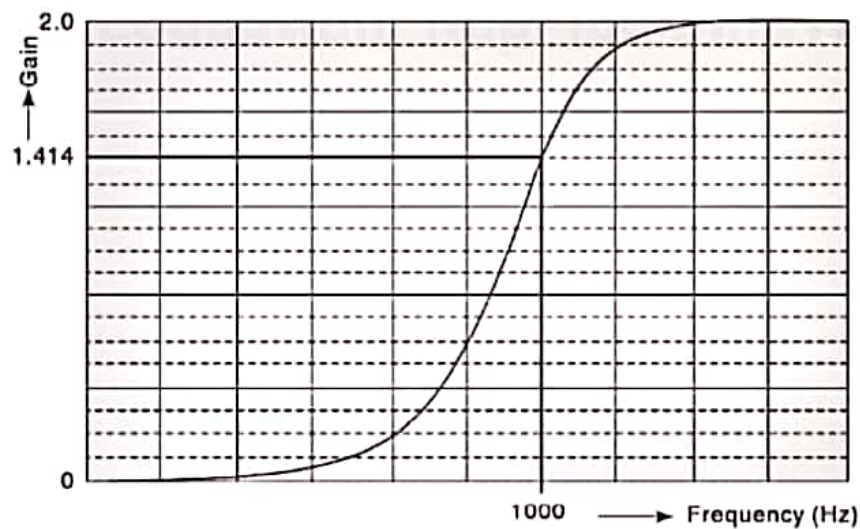
**Figure 9.12(b)** Filter characteristics of Example (9.2)

Frequency (Hz)	Gain	Gain (in dB)
100	0.20	-14.02
200	0.39	-9.13
400	0.74	-2.58
700	1.15	1.19
1,000	1.41	3.01
3,000	1.90	5.56
7,000	1.98	5.93
10,000	1.99	5.98
30,000	2	6.02
100,000	2	6.02

## 9.8 BAND-PASS ACTIVE FILTER

A band-pass filter has a pass-band between two cut-off frequencies  $f_{cl}$  (lower cut-off frequency) and  $f_{cu}$  (upper cut-off frequency) such that  $f_{cu} > f_{cl}$ . Any input frequency outside this pass-band is attenuated.

### 9.8.1 Bandwidth (BW)

The range of frequency between  $f_{cl}$  and  $f_{cu}$  is called the bandwidth.

$$BW = (f_{cu} - f_{cl})$$

The bandwidth is not exactly centered on the resonant frequency ( $f_r$ ). If  $f_{cu}$  and  $f_{cl}$  are known, the resonant frequency can be found from,

$$f_r = \sqrt{f_{cl} \cdot f_{cu}}$$

If ' $f_r$ ' and BW are known, cut-off frequencies are found from,

$$f_{cl} = \left( \sqrt{\left(\frac{BW}{2}\right)^2 - f_r^2} \right) - \left(\frac{BW}{2}\right)$$

$$f_{cu} = (f_{cl} + BW)$$

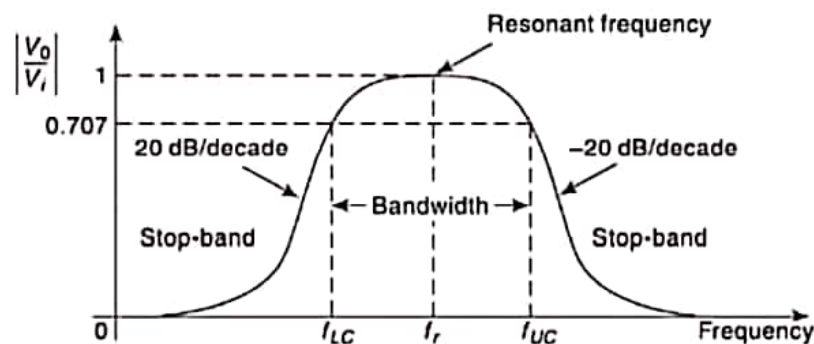

Figure 9.13 Band pass filter characteristics

### 9.8.2 Quality Factor (Q)

It is defined as the ratio of resonant frequency to bandwidth, i.e.,  $Q = \frac{f_r}{BW}$

$Q$  is a measure of the selectivity. Higher the value of  $Q$ , the more selective is the filter, i.e., narrower is the bandwidth.

**Example 9.3** A band-pass voice filter has lower and upper cut-off frequencies of 300 and 3000 Hz, respectively. Find (a) Bandwidth, (b) The resonant frequency, (c) The quality factor.

*Solution* (a)  $BW = (f_{CU} - f_{CL}) = (3000 - 300) = 2700$  Hz *Ans.*

(b)  $f_r = \sqrt{f_{CL} \cdot f_{CU}} = \sqrt{300 \times 3000} = 950$  Hz *Ans.*

(c)  $Q = \frac{f_r}{BW} = \frac{950}{2700} = 0.35$  *Ans.*

[Note  $f_r$  is below the centre frequency  $\frac{300 + 3000}{2} = 1650$  Hz]

**Example 9.4** A band-pass filter has a resonant frequency of 950 Hz and a bandwidth of 2700 Hz. Find its lower and upper cut-off frequencies.

*Solution*

$$f_{CL} = \left( \sqrt{\left(\frac{BW}{2}\right)^2 + f_r^2} \right) - \left(\frac{BW}{2}\right)$$

$$= \left( \sqrt{\left(\frac{2700}{2}\right)^2 + (950)^2} \right) - \left(\frac{2700}{2}\right) = (1650 - 1350)$$

$$= 300 \text{ Hz}$$

*Ans.*

$$\therefore f_{cu} = (300 + 2700) = 3000 \text{ Hz}$$

### 9.8.3 Types of Band-Pass Filters

1. **Wide Band-Pass Filter** wide-band filter has a bandwidth that is two or more times the resonant frequency; i.e.,  $Q \leq 0.5$ .

It is made by cascading a low-pass and a high-pass filter circuit.

2. **Narrow Band-Pass Filter** A narrow band filter has a quality factor,  $Q > 0.5$ .

It is made by using a single op-amp and multiple feed back circuits.

**Wide Band-Pass Active Filter** In general, a wide-band filter ( $Q \leq 0.5$ ) is made by cascading a low-and a high-pass filter, provided the cut-off frequency of the low-pass section is greater than that for the high-pass section.

Where,  $A_{FL}$ ,  $A_{FH}$  = Pass-band gain of low-pass and high-pass filter;

$f$  = frequency of input signal (Hz);

$f_{cl}$  = lower cut-off frequency (Hz);

$f_{cu}$  = higher cut-off frequency (Hz);

At the centre frequency,  $f_r (= \sqrt{f_{CL} f_{CU}})$ , the Gain is,  $\left| \frac{V_0}{V_i} \right| = K = A_{FL} A_{FH} \frac{f_{CU}}{f_{CL} + f_{CU}}$

$$\text{At } f = f_{CL}, \quad \left| \frac{V_0}{V_i} \right| = \frac{A_{FL} A_{FH} (f_{CL}/f_{CL})}{\sqrt{[1 + (f_{CL}/f_{CL})^2][1 + (f_{CL}/f_{CU})^2]}} = \frac{A_{FL} A_{FH}}{\sqrt{(2)[1 + (f_{CL}/f_{CU})^2]}}$$

$$\left| \frac{V_0}{V_i} \right| = \frac{A_{FL} A_{FH} f_{CU}}{\sqrt{2} \sqrt{f_{CL}^2 + f_{CU}^2}}$$

$$\text{At } f = f_{CU}, \quad \left| \frac{V_0}{V_i} \right| = \frac{A_{FL} A_{FH} (f_{CU}/f_{CL})}{\sqrt{(2)[1 + (f_{CL}/f_{CL})^2]}} = \frac{A_{FL} A_{FH} f_{CU}}{\sqrt{2} \sqrt{f_{CL}^2 + f_{CU}^2}}$$

$$\text{At } f = f_{CL} = f_{CU}, \quad \text{Gain, } \left| \frac{V_0}{V_i} \right| = \frac{A_{FL} A_{FH}}{\sqrt{2}} \left[ \frac{f_{CU}}{\sqrt{f_{CL}^2 + f_{CU}^2}} \right]$$

$$\Rightarrow \quad \frac{V_0}{V_i} = \frac{A_{FL} A_{FH}}{2}$$

**Narrow Band-pass Active Filter** In general, a narrow band-pass filter is made by using multiple feedback circuit with a single op-amp.

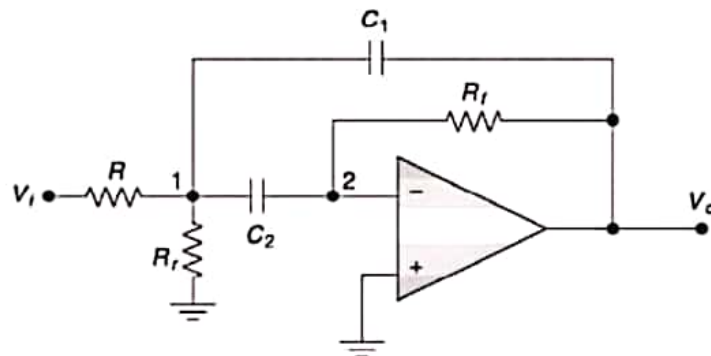

Figure 9.15 Multiple feedback narrow BP active filter

Compared to all other filters, it has some unique features, as given below.

- (i) It has two feedback paths, hence the name 'multiple feedback filter'.
- (ii) The op-amp is used in the inverting mode.
- (iii) Its centre frequency can be changed without changing the gain or bandwidth.

**Performance Equations**

Writing KCL at (1)

$$\frac{(V_1 - V_i)}{R} + \frac{V_1 - V_0}{1/sC_1} + \frac{V_1 - 0}{1/sC_2} + \frac{V_1}{R_r} = 0$$

$$\text{or } (V_1 - V_i) R_r + (V_1 - V_0) sR_r R C_1 + V_1 sR_r R C_2 + V_1 R = 0$$

$$\text{or } V_1 = \frac{V_i R_r + V_0 sR_r R C_1}{R + R_r + sR_r R (C_1 + C_2)} \quad (9.5)$$

Again, writing KCL at (2),

$$\frac{0 - V_0}{R_f} + \frac{0 - V_1}{1/sC_2} = 0$$

$$\text{or } V_0 = -V_1 sR_f C_2$$

$$= - \left[ \frac{V_i R_r + V_0 sR_r R C_1}{R + R_r + sR_r R (C_1 + C_2)} \right] sR_f C_2 \text{ \{by the value of } V_1 \text{ from (9.5)\}}$$

$$\text{or } V_0 [R + R_r + sR_r R (C_1 + C_2) + s_2 R_r R_f C_1 C_2] = -V_i sR_r R_f C_2$$

$$\therefore \frac{V_0}{V_i} = - \frac{sR_r R_f C_2}{s^2 R_r R_f C_1 C_2 + sR_r R (C_1 + C_2) + R + R_r}$$

So, the gain,

$$\boxed{\frac{V_0}{V_i} = - \frac{(s/R C_1)}{s^2 + s \left( \frac{C_1 + C_2}{R_f C_1 C_2} \right) + \frac{R + R_r}{R_r R_f C_1 C_2}}$$

The general transfer function is of the form,

$$\frac{V_0}{V_i} = - \frac{s \left( \frac{\omega_r}{Q} \right)}{s^2 + s \left( \frac{\omega_r}{Q} \right) + \omega_r^2} = - \frac{s(\text{BW})A_F}{s^2 + s(\text{BW}) + \omega_r^2}, \text{ where, } A_F = \text{Gain}$$

$$\text{So, here, BW} = \left( \frac{C_1 + C_2}{R_f C_1 C_2} \right) \times \frac{1}{2\pi} \text{ (in Hz) } \{ \because \omega = 2\pi f \}$$

With matched capacitor, i.e.,  $C_1 = C_2 = C$ 

$$\text{BW} = \frac{1}{\pi R_f C} \Rightarrow R_f = \frac{Q}{\pi f C}$$

$$\text{Also, } (\text{BW})A_F = \frac{1}{RC_1} = \frac{1}{RC} \mid \text{ with } C_1 = C_2 = C$$



**Example 9.6**

- (a) Design a narrow band-pass filter with resonant frequency  $f_r = 1$  kHz,  $Q = 3$ , and  $A_F = 10$ .  
 (b) Change the resonant frequency to 1.5 kHz, keeping  $A_F$  and the bandwidth constant.

**Solution**

- (a) Let,  $C_1 = C_2 = 0.01 \mu\text{F}$

$$R_f = \frac{Q}{\pi f_r C} = \frac{3}{\pi \times 10^3 \times 10^{-8}} = 95.5 \text{ k}\Omega ;$$

$$R = \frac{Q}{2\pi f_r C A_F} = \frac{3}{2\pi \times 10^3 \times 10^{-8} \times 10} = 4.77 \text{ k}\Omega$$

$$R_r = \frac{Q}{2\pi f_r C (2Q^2 - A_F)} = \frac{4.77 \times 10}{(2 \times 9 - 10)} = 5.97 \text{ k}\Omega$$

- (b) To change the resonant frequency, the resistance value will be,

$$R' = 5.97 \times 10^3 \times \left(\frac{1}{1.5}\right) = 3.98 \text{ k}\Omega$$

The frequency response is shown below.

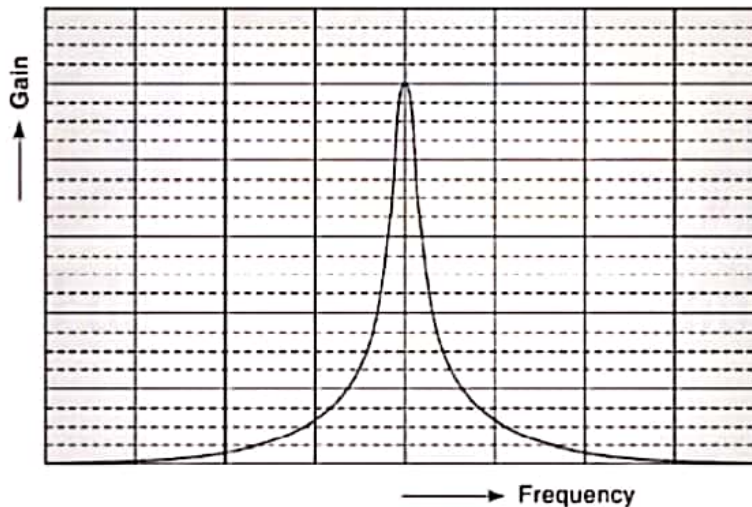

Figure 9.17 Frequency response of Example (9.6)

**Example 9.7**

A band-pass filter has the component values,  $R = 21.12 \text{ k}\Omega$ ,  $R_f = 42.42 \text{ k}\Omega$ ,  $R_r = 3.03 \text{ k}\Omega$  and  $C_1 = C_2 = 0.015 \mu\text{F}$ . Find the resonant frequency and the bandwidth.

**Solution**

Here, since  $R_f = 2R$ , so,  $A_F = 1$ .

$$\therefore f_r = \frac{0.1125}{RC} \sqrt{\frac{1}{A_F} \left(1 + \frac{R}{R_r}\right)} = \frac{0.1125}{21.12 \times 10^3 \times 0.015 \times 10^{-6}} \sqrt{1 + \frac{21.21}{3.03}} \cong 1000 \text{ Hz}$$

$$BW = \frac{0.1591}{A_F RC} = \frac{0.1591}{1 \times 21.21 \times 10^3 \times 0.015 \times 10^{-6}} \cong 500 \text{ Hz}$$

## 9.9 BAND-REJECT (NOTCH) ACTIVE FILTER

- It may be obtained by the parallel connection of a high-pass section with a low-pass section. The cut-off frequency of the high-pass section must be greater than that of the low-pass section.

The outputs of HP and LP sections are fed to an adder whose output voltage  $V_o$  will have the notch filter characteristics.

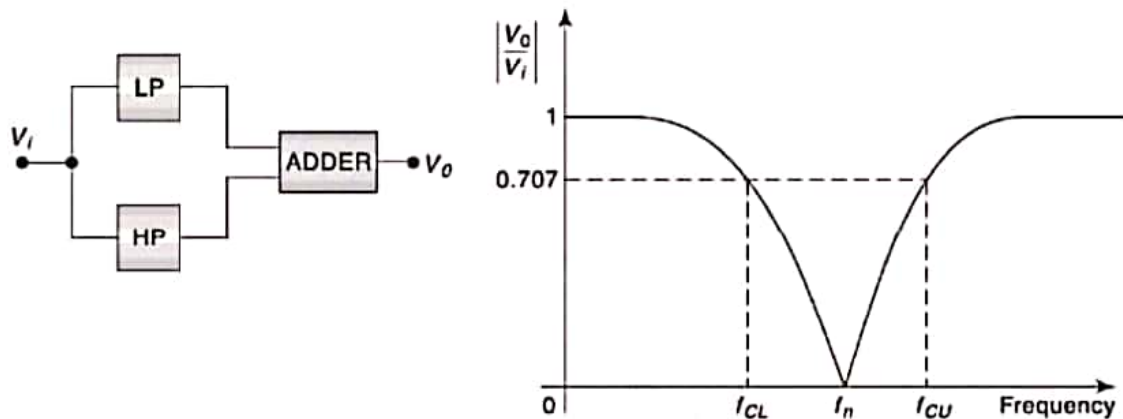

Figure 9.18(a) Block diagram of BR filter

Figure 9.18(b) Frequency response of band reject filter

The circuit of the BR filter is shown in Fig. 9.19.

Obviously, the gain of the adder is set at unity; and thus,

$$V_o = \left( \frac{V_o'}{R_2} + \frac{V_o''}{R_3} \right) R_4 \Rightarrow R_2 = R_3 = R_4$$

and  $R_{OM} = R_2 \parallel R_3 \parallel R_4$

So, 
$$V_o = A_{FH} \left[ \frac{j(f/f_{CH})}{1 + j(f/f_{CH})} \right] + A_{FL} \left[ \frac{1}{1 + j(f/f_{CL})} \right]$$

If  $A_{FL} = A_{FH} = A$ , then at the center frequency,  $f_r = \sqrt{f_{CL} f_{CH}}$ , the Gain is  $K = A \cdot \frac{2f_{CL}}{f_{CL} + f_{CH}}$

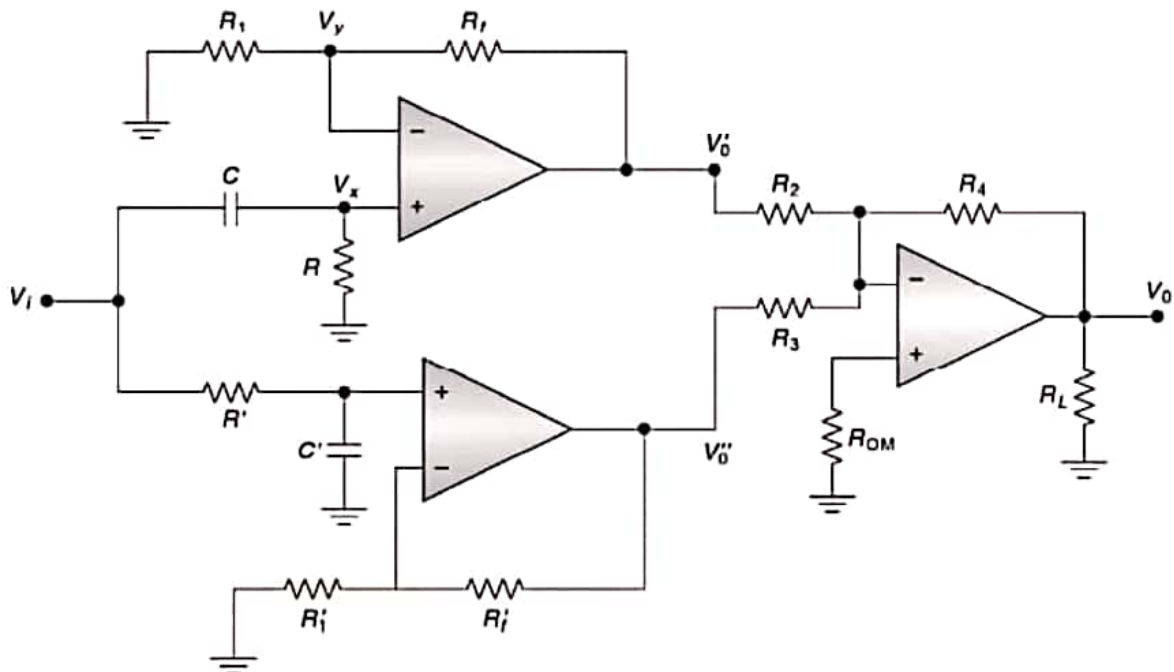

**Figure 9.19** Band reject active filter circuit using parallel connection of high pass and low pass filters

- Band-reject filter may also be obtained by using the multiple-feedback band-pass filter circuit with an adder. That is, the notch filter is made by a circuit that subtracts the output of a band pass filter from the original signal.

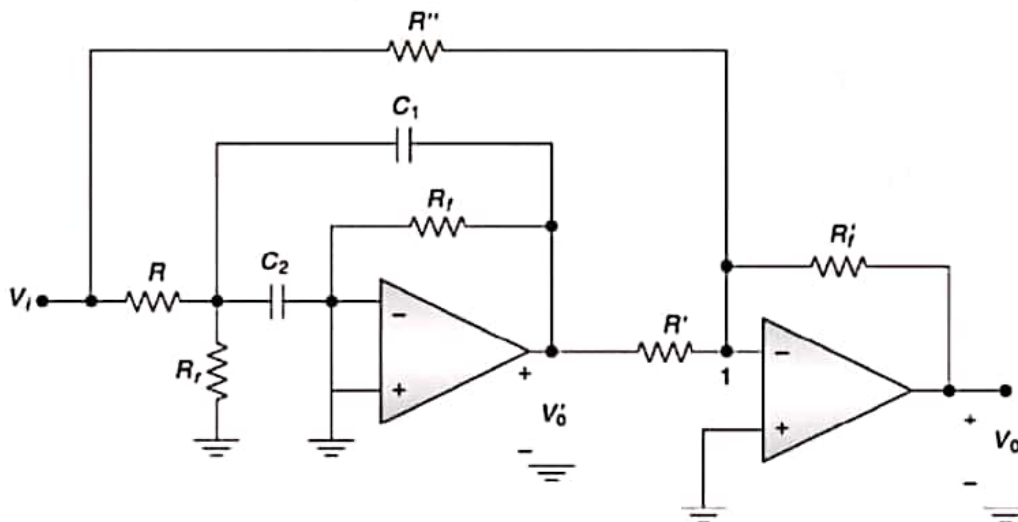

**Figure 9.20** Band reject active filter circuit using multiple feedback band pass filter with an adder

So,

$$\frac{V_0'}{V_i} = - \frac{(s/RC_1)}{s^2 + s \left( \frac{C_1 + C_2}{R_f C_1 C_2} \right) + \frac{R + R_r}{R R_f C_1 C_2}} = T(s)$$

Now, writing KCL at (1),

$$\frac{V_0'}{R'} + \frac{V_0}{R_f} + \frac{V_i}{R''} = 0$$

$$\begin{aligned} \Rightarrow V_0 &= -R_f \left( \frac{V_0'}{R''} + \frac{V_0'}{R'} \right) \\ &= -R_f V_i \left[ \frac{1}{R''} + \frac{T(s)}{R'} \right] \end{aligned}$$

At notch frequency, the output is zero (ideally).

$$\text{So, } T(s) = -\frac{R'}{R''}$$

But, at  $\omega_n$  (or  $f_n$ ),  $T(s) = -A_F$  ( $A_F$  = gain of the BP section)

With  $C_1 = C_2$ , Gain for BP section,  $A_F = \frac{R_f}{2R}$

$$\therefore A_F = \frac{R_f}{2R} = \frac{R'}{R''}$$

So, the design equations are all those of BP section and this one.

**Example 9.8** Design a notch filter having a resonant frequency,  $f_r = 400$  Hz and  $Q = 10$ . Make the resonant frequency gain,  $A_F = 2$ .

**Solution** Here,  $f_r = 400$  Hz,  $Q = 10$ ,  $A_F = 2$   
Let,  $C = 0.1 \mu\text{F}$

$$\therefore R = \frac{Q}{2\pi f_r C A_F} = \frac{10}{2\pi \times 400 \times 0.1 \times 10^{-6} \times 2} = 19.89 \text{ k}\Omega \quad \text{Ans.}$$

$$\therefore R_f = \frac{Q}{\pi f_r C} = \frac{10}{\pi \times 400 \times 0.1 \times 10^{-6}} = 79.58 \text{ k}\Omega$$

$$\therefore R_r = \frac{R A_F}{2Q^2 - A_F} = \frac{19.89 \times 2 \times 10^3}{200 - 2} = 202 \Omega$$

Let,  $R' = 1 \text{ k}\Omega$  (arbitrary) =  $R_f'$

$$R'' = \frac{R'}{A_F} = 500 \Omega \quad \text{Ans.}$$

### 9.9.1 Applications of Notch Filters

Notch filter is used where unwanted frequencies are to be attenuated while permitting the other signal frequencies to pass through.

For examples, 50 Hz, 60 Hz, or 400 Hz frequencies from power lines, ripple from a full-wave rectifiers, etc.

**Example 9.9** Design an active notch filter to eliminate 120 Hz hum (noise). Take the bandwidth,  $BW = 12$  Hz.

*Solution* Here,  $f_r = 120$  Hz,  $BW = 12$  Hz,  $Q = \frac{120}{12} = 10$

The gain of the filter in the pass-band will be maximum of 1,

$$AF = 1.$$

Let,  $C_1 = C_2 = 0.1 \mu\text{F}$

$$R = \frac{10}{2\pi \times 120 \times 0.1 \times 10^{-6} \times 1} = 132.66 \text{ k}\Omega$$

$$R_f = 2R = 265.32 \text{ k}\Omega$$

$$R_r = \frac{R}{200 - 1} = 663.3 \text{ k}\Omega$$

Now, let  $R' = R'_f = 1 \text{ k}\Omega$  (arbitrary)

So,  $R'' = \frac{R'}{A_f} = 1 \text{ k}\Omega$

Thus the filter will pass all frequencies from (0 – 114) Hz and 126 Hz onwards.

## 9.10 FILTER APPROXIMATION

In the earlier sections, we saw several examples of amplitude response curves for various filter types. These always included an “ideal” curve with a rectangular shape, indicating that the boundary between the pass-band and the stop-band was abrupt and that the roll-off slope was infinitely steep. This type of response would be ideal because it would allow us to completely separate signals at different frequencies from one another. Unfortunately, such an amplitude response curve is not physically realizable. We will have to settle for the best approximation that will still meet our requirements for a given application. Deciding on the best approximation involves making a compromise between various properties of the filter’s transfer function, such as, filter order, ultimate roll-off rate, attenuation rate near the cut-off frequency, transient response, ripples, etc.

If we can define our filter requirements in terms of these parameters, we will be able to design an acceptable filter using standard design methods.

### 9.10.1 Butterworth Filters

The first and probably best-known filter approximation is the Butterworth or maximally-flat response. It exhibits a nearly flat pass-band with no ripple. The roll-off is smooth and monotonic, with a low-pass or high-pass roll-off rate of 20 dB/decade (6 dB/octave) for every pole. Thus, a 5<sup>th</sup>-order

Butterworth low-pass filter would have an attenuation rate of 100 dB for every factor of ten increase in frequency beyond the cutoff frequency.

The general equation for a Butterworth filter's amplitude response is,

$$H(\omega) = \frac{1}{1 + \left(\frac{\omega}{\omega_0}\right)^{2n}} \quad (9.9)$$

where  $n$  is the order of the filter, and can be any positive whole number (1, 2, 3,...), and  $\omega_0$  is the -3 dB frequency of the filter.

Figure 9.21 shows the amplitude response curves for Butterworth low-pass filters of various orders.

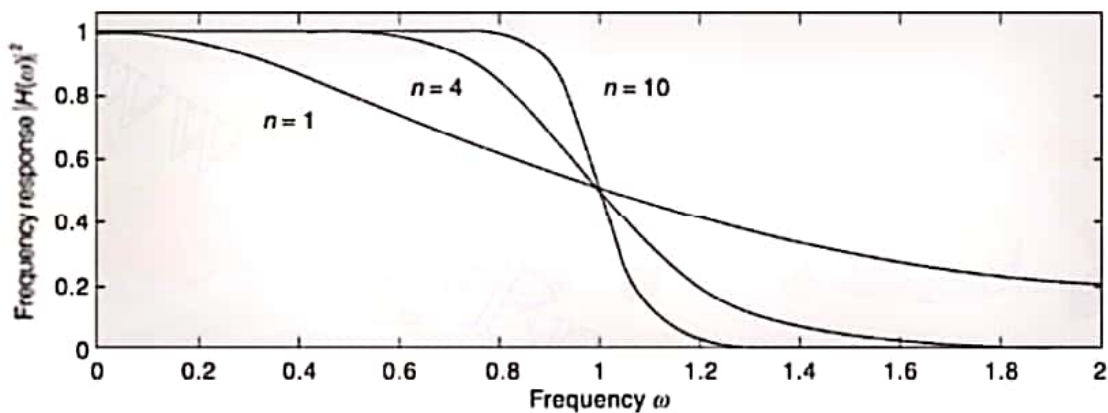

Figure 9.21 Amplitude response curves for butterworth low-pass filters of different orders

The coefficients for the denominators of Butterworth filters of various orders are shown in table. Table shows the denominators factored in terms of second-order polynomials. Again, all of the coefficients correspond to a corner frequency of 1 radian/s

Table 9.1 Butterworth Polynomials

Denominator coefficients for polynomials of the form  $s^n + a_{n-1}s^{n-1} + a_{n-2}s^{n-2} + \dots + a_1s + a_0$

$n$	$a_0$	$a_1$	$a_2$	$a_3$	$a_4$	$a_5$	$a_6$	$a_7$	$a_8$	$a_9$
1	1									
2	1	1.414								
3	1	2.000	2.000							
4	1	2.613	3.414	2.613						
5	1	3.236	5.236	5.236	3.236					
6	1	3.864	7.464	9.147	7.464	3.864				
7	1	4.494	10.098	14.592	14.592	10.098	4.494			
8	1	5.126	13.137	21.846	25.688	21.846	13.137	5.126		
9	1	5.759	16.582	31.163	41.986	41.986	31.163	16.582	5.759	
10	1	6.392	20.432	42.802	64.882	74.233	64.882	42.802	20.432	6.392

## Butterworth Quadratic Factors

$n$	
1	$(s + 1)$
2	$(s^2 + 1.4142s + 1)$
3	$(s + 1)(s^2 + s + 1)$
4	$(s^2 + 0.7654s + 1)(s^2 + 1.8478s + 1)$
5	$(s + 1)(s^2 + 0.6180s + 1)(s^2 + 1.6180s + 1)$
6	$(s^2 + 0.5176s + 1)(s^2 + 1.4142s + 1)(s^2 + 1.9319)$
7	$(s + 1)(s^2 + 0.4450s + 1)(s^2 + 1.2470s + 1)(s^2 + 1.8019s + 1)$
8	$(s^2 + 0.3902s + 1)(s^2 + 1.1111s + 1)(s^2 + 1.6629s + 1)(s^2 + 1.9616s + 1)$
9	$(s + 1)(s^2 + 0.3479s + 1)(s^2 + 1.0000s + 1)(s^2 + 1.5321s + 1)(s^2 + 1.8794s + 1)$
10	$(s^2 + 0.3129s + 1)(s^2 + 0.9080s + 1)(s^2 + 1.4142s + 1)(s^2 + 1.7820s + 1)(s^2 + 1.9754s + 1)$

### 9.10.2 Second Order Low-pass Active Filter

The circuit is shown in Figure 9.22.

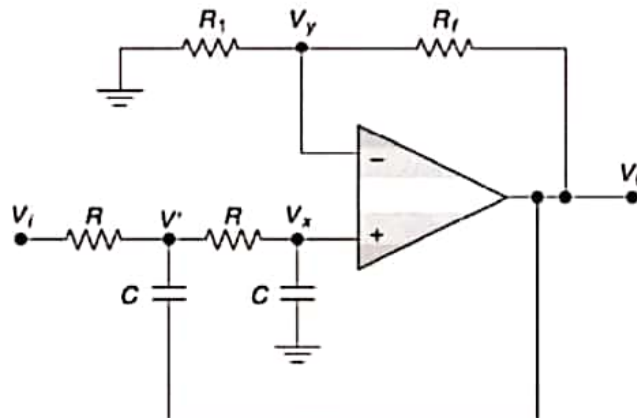

Figure 9.22 Second order low-pass active filter

Here,  $V_y = \frac{V_o}{R_1 + R_f} R_1$  and  $V_x = V_y$

Writing KCL at node  $V'$ ,

$$\frac{V' - V_i}{R} + \frac{V' - V_o}{1/sC} + \frac{V' - V_x}{R} = 0$$

or  $(V' - V_i) + (V' - V_o)sRC + (V' - V_x) = 0$

or  $(-1)V_x + (2 + sRC)V' + (-sRC)V_o = V_i$  (9.10)

Writing KCL at node  $x$ ,

$$\frac{V_x - V'}{R} + \frac{V_x}{1/sC} = 0$$

or  $(1 + sRC)V_x + (-1)V' + (0)V_o = 0$  (9.11)

Writing KCL at node  $y$ ,

$$\frac{V_x}{R_1} + \frac{V_x - V_0}{R_f} = 0$$

$$\text{or} \quad (R_1 + R_f)V_x + (0)V' + (-R_1)V_0 = 0 \quad (9.12)$$

Solving for  $V_0$  from equations (9.10), (9.11), and (9.12), we get,

$$V_0 = \frac{\begin{vmatrix} -1 & (2 + sRC) & V_i \\ (1 + sRC) & -1 & 0 \\ (R_1 + R_f) & 0 & 0 \end{vmatrix}}{\begin{vmatrix} -1 & (2 + sRC) & -sRC \\ (1 + sRC) & -1 & 0 \\ (R_1 + R_f) & 0 & -R_1 \end{vmatrix}} = V_i \frac{\frac{(R_1 + R_f)}{R_1} \times \frac{1}{R^2 C^2}}{s^2 + 3sRC - sRC \left( \frac{(R_1 + R_f)}{R_1} \right) + \frac{1}{R^2 C^2}}$$

$$\text{or,} \quad \frac{V_0(s)}{V_i(s)} = \frac{\frac{K}{R^2 C^2}}{s^2 + s \left( \frac{3 - K}{RC} \right) + \left( \frac{1}{RC} \right)^2} \quad (9.13)$$

where,  $K = \frac{R_1 + R_f}{R_1}$  = DC gain of the amplifier.

Substituting  $s = j\omega$ , the transfer function is,

$$H(j\omega) = \frac{V_0(j\omega)}{V_i(j\omega)} = \frac{K}{1 + j(3 - K)RC\omega - R^2 C^2 \omega^2}$$

The magnitude of the transfer function is,

$$|H(j\omega)| = \frac{K}{\sqrt{\left[ 1 - \left( \frac{\omega}{\omega_c} \right)^2 \right]^2 + [3 - K]^2 \left( \frac{\omega}{\omega_c} \right)^2}}; \text{ where, } \omega_c = \frac{1}{RC}$$

In the above equation, when  $\omega \rightarrow 0$ ,  $|H(j\omega)| = K$ . Thus, the low frequency gain of the filter is  $K$  and when  $\omega \rightarrow \infty$ ,  $|H(j\omega)| = 0$ , i.e., high frequency gain is zero.

From the Table of the Butterworth Filter, the transfer function for second order ( $n = 2$ ) filter is,

$$T(s) = \frac{K}{\left( \frac{s}{\omega_c} \right)^2 + 1.414 \left( \frac{s}{\omega_c} \right) + 1} = \frac{K \omega_c^2}{s^2 + 1.414 \omega_c s + \omega_c^2} \quad (9.14)$$

where,  $\omega_c$  is the cut-off frequency. Comparing equations (9.13) and (9.14), we get,

$$\boxed{\omega_c = \frac{1}{RC} \quad \text{or,} \quad f_c = \frac{1}{2\pi RC}} \quad \text{and,} \quad \boxed{K = (3 - 1.414) = 1.586}$$



The frequency response of a second order low-pass active filter is shown in Figure 9.23. It is noted that the filter has very sharp roll-off response.

### Filter Design

1. Choose a value of the cut-off frequency,  $\omega_c$  (or  $f_c$ ).
2. Select a convenient value for the capacitors  $C$ , between 100 pF and 0.1  $\mu$ F.
3. Calculate the value of the resistors  $R$  from the relation,

$$R = \frac{1}{2\pi f_c C}$$

4. For minimization of dc offset, the feedback resistor is calculated from the relation,  $R_f = K(2R) = 3.172R$ .
5. Calculate the value of the resistor  $R_1$  for the value of the gain  $K = 1.586$  from the relation,

$$K = \frac{R_1 + R_f}{R_1}, \text{ i.e., } R_1 = \frac{R_f}{0.586}.$$

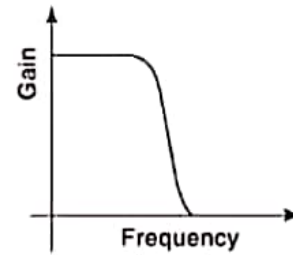

Figure 9.23 Frequency response of the second order low-pass filter

### Example 9.10

Design a second-order low-pass filter with a gain of 11 and cut-off frequency of 20 kHz.

### Solution

Let us arbitrarily select  $C = 200$  pF.

For a cut-off frequency of 20 kHz, we need  $R = \frac{1}{2\pi f_c C} = \frac{1}{2\pi \times 20 \times 10^3 \times 200 \times 10^{-12}}$   
 $= 39.789$  k $\Omega$

If we select a standard resistor of 39 k $\Omega$  for  $R$ , then the cut-off frequency is about 20.4 kHz.

The dc gain for this filter cannot be anything other than  $K$  where  $K = 1.586$ .

Thus, for a dc gain of 1.586,  $K = 1 + R_f/R_1 = 1.586$ .

This in turn implies that  $R_f = 0.586 R_1$ .

Imposing the dc bias-current balance condition, we obtain

$$0.586 R_1 = 1.586 (2R) = 123.708 \text{ k}\Omega.$$

Consequently,  $R_1 = 211.11$  k $\Omega$  and  $R_f = 123.708$  k $\Omega$ .

Let us select a standard value of 130 k $\Omega$  for  $R_f$ . Then  $R_1$  should be about 221.8 k $\Omega$ .

We need another amplifying stage to obtain the needed gain of 11. The gain of this stage should be  $11/K = 6.936$ . We have chosen to use non-inverting amplifier for this stage. The output amplifier resistors are calculated as,

$$6.936 = \left(1 + \frac{R_2}{R_A}\right) \text{ and for } R_A = 100 \text{ k}\Omega, R_2 = 593.6 \text{ k}\Omega.$$

Thus, the final circuit for the second order low-pass active filter becomes as shown in Fig. 9.24.

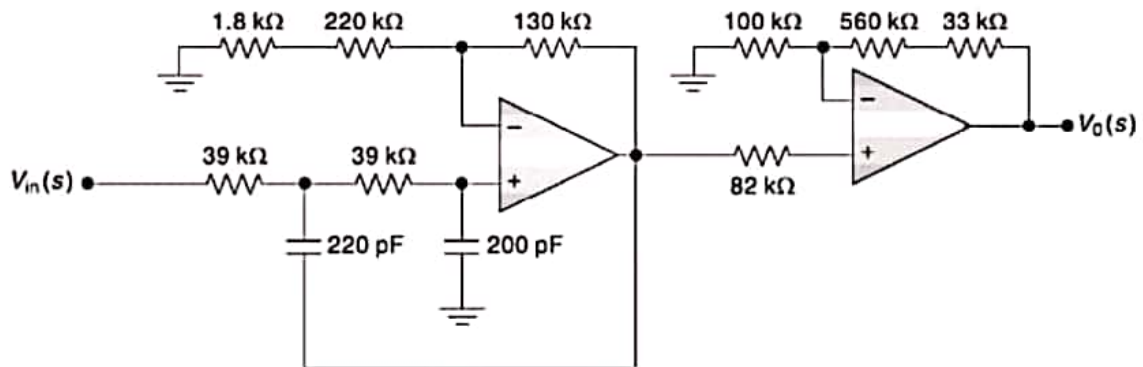

Figure 9.24 Circuit of Example (9.10)

### 9.10.3 Second Order High Pass Active Filter

The circuit is shown in Figure 9.25.

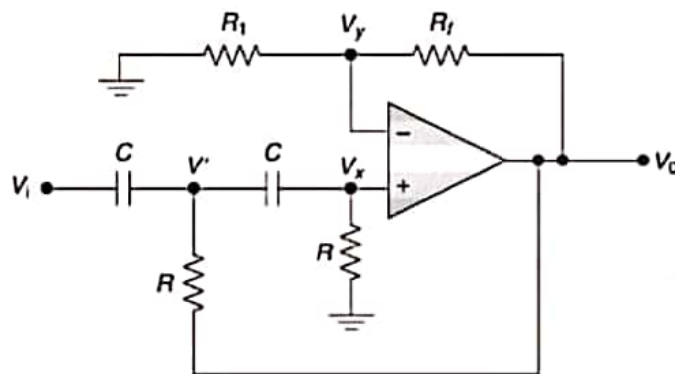

Figure 9.25 Second order high-pass filter

Here,  $V_y = \frac{V_o}{R_1 + R_f} R_1$  and  $V_x = V_y$

Writing KCL at node  $V'$ ,

$$\frac{V' - V_i}{1/sC} + \frac{V' - V_o}{R} + \frac{V' - V_x}{1/sC} = 0 \quad (9.15)$$

Writing KCL at node  $x$ ,

$$\frac{V_x - V'}{1/sC} + \frac{V_x}{R} = 0 \quad (9.16)$$

Writing KCL at node  $y$ ,

$$\frac{V_x}{R_1} + \frac{V_x - V_0}{R_f} = 0 \quad (9.17)$$

Solving for  $V_0$  from equations (9.15), (9.16), and (9.17), we get,

$$\text{or, } \frac{V_0(s)}{V_i(s)} = \frac{Ks^2}{s^2 + s\left(\frac{3-K}{RC}\right) + \left(\frac{1}{RC}\right)^2} \quad (9.18)$$

where,  $K = \frac{R_1 + R_f}{R_1} = \text{DC gain of the amplifier.}$

**Note** The transfer function of the high-pass filter can also be obtained from the transfer function of

the low-pass filter by the transformation  $\left(\frac{s}{\omega_c}\right)\Big|_{LP} \rightarrow \left(\frac{\omega_c}{s}\right)\Big|_{HP}$

Substituting  $s = j\omega$ , the transfer function is,

$$H(j\omega) = \frac{V_0(j\omega)}{V_i(j\omega)} = -\frac{KR^2C^2\omega^2}{1 + j(3-K)RC\omega - R^2C^2\omega^2}$$

The magnitude of the transfer function is,

$$|H(j\omega)| = \frac{K\left(\frac{\omega}{\omega_c}\right)^2}{\sqrt{\left[1 - \left(\frac{\omega}{\omega_c}\right)^2\right]^2 + [3-K]^2\left(\frac{\omega}{\omega_c}\right)^2}}; \text{ where, } \omega_c = \frac{1}{RC}$$

In the above equation, when  $\omega \rightarrow 0$ ,  $|H(j\omega)| = 0$ . Thus, the low frequency gain of the filter is zero.

When  $\omega \rightarrow \infty$ ,  $|H(j\omega)| = K$ , i.e., high frequency gain is  $K$ .

Here, again, comparing with Butterworth Transfer function, we get,

$$\omega_c = \frac{1}{RC} \quad \text{or,} \quad f_c = \frac{1}{2\pi RC}$$

$$K = (3 - 1.414) = 1.586$$

The frequency response of a second order low-pass active filter is shown below. It is noted that the filter has very sharp roll-off response.

The design procedure for high-pass will be same as low-pass.

The frequency response will be a maximally flat one, i.e., having a very sharp roll-off response.

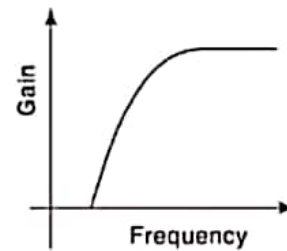

Figure 9.26 Gain vs. frequency plot of a second-order high-pass filter

**Example 9.11** A second-order high-pass filter is given in Figure 9.27. Determine its cut-off frequency and high frequency gain. Sketch its gain vs. frequency response.

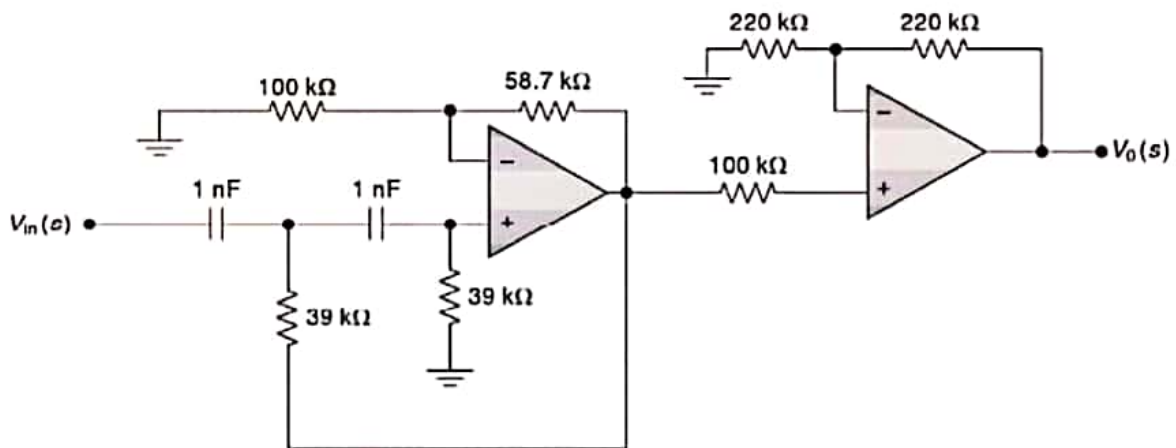

Figure 9.27 Circuit of Example (9.11)

**Solution**

In the second-order filter on the left side of the figure, the gain  $K$  is

$$= \left(1 + \frac{58.7}{100}\right) = 1.587.$$

Since it is very close to 1.586, we can assume that the filter is maximally flat and its transfer function is as given for Butterworth filters. From the given values of  $R$  and  $C$ , the cut-off frequency is,

$$\omega_c = \frac{1}{RC} = \frac{1}{39 \times 10^3 \times 1 \times 10^{-9}} = 25,641 \text{ rad/s}$$

The cut-off frequency in Hz,  $f_c = \frac{25,641}{2\pi} = 4081 \text{ Hz}$

The gain of the non-inverting amplifier,  $A = \left(1 + \frac{220}{220}\right) = 2$

Hence, the overall gain of the high-pass filter is,

$$A_H = 1.587 \times 2 = 3.174 \text{ or approximately } 10 \text{ dB.}$$

The gain vs. frequency will be as shown in Figure 9.26.

### 9.10.4 Second Order Band-Pass Active Filter

It can be built by the cascade connection of a second order high-pass and a second order low-pass filter.

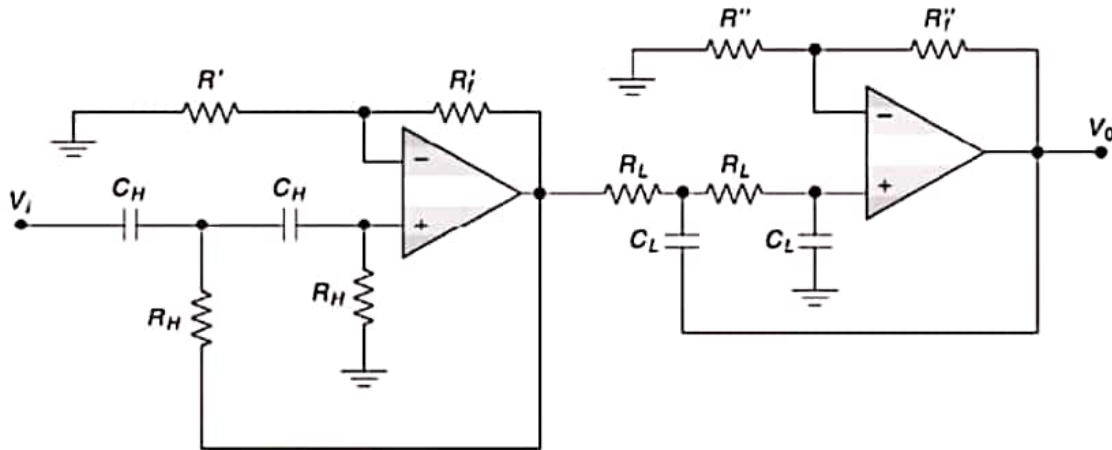

Figure 9.28 Second-order band-pass active filter circuit

Lower cut-off frequency,  $\omega_1 = \frac{1}{R_H C_H}$

Upper cut-off frequency,  $\omega_2 = \frac{1}{R_L C_L}$

Voltage gains,  $K_H = \left[1 + \frac{R_f'}{R'}\right]$  and  $K_L = \left[1 + \frac{R_f''}{R''}\right]$

For maximally flat response (or, Butterworth) filter,  $K_H = K_L = 1.586$ .

$$\therefore \frac{R_f'}{R'} = \frac{R_f''}{R''} = 0.586$$

The overall transfer function is the product of the transfer function of the high-pass and low-pass filters.

$$\therefore H(s) = \frac{K_H \left(\frac{s}{\omega_1}\right)}{1 + \left(\frac{s}{\omega_1}\right)^2 + (3 - K_H) \left(\frac{s}{\omega_1}\right)} \times \frac{K_L}{1 + \left(\frac{s}{\omega_2}\right)^2 + (3 - K_L) \left(\frac{s}{\omega_2}\right)}$$

Substituting the values of  $K_H$  and  $K_L$ , magnitude of the gain is,

$$|H(j\omega)| = \frac{2.5154 \left(\frac{\omega}{\omega_1}\right)^2}{\sqrt{1 + \left(\frac{\omega}{\omega_2}\right)^4} \sqrt{1 + \left(\frac{\omega}{\omega_1}\right)^4}}$$

**Note** In the pass-band, the gain is 2.5154.

The frequency response is more flat near the cut-off frequencies.

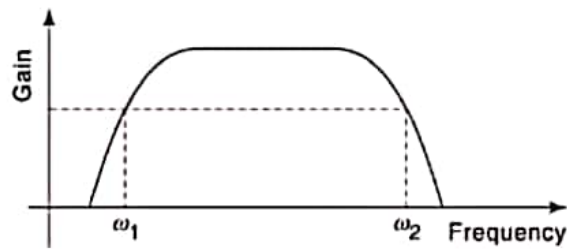

Figure 9.29 Frequency response of second order band-pass filter

### 9.10.5 Second Order Band-Reject Active Filter

It can be built by the summation of a second order high-pass and a second order low-pass filter.

The cut-off frequency of LPF,  $\omega_1 = \frac{1}{R_L C_L}$  and the cut-off frequency of HPF,  $\omega_2 = \frac{1}{R_H C_H}$ .

The magnitude of the overall transfer function is the sum of the transfer function of the high-pass and low-pass filters,

$$|H(j\omega)| = \frac{1}{2} \left[ 1 + \frac{R_2}{R_1} \right] \left[ \frac{K_H \left( \frac{\omega}{\omega_2} \right)^2}{\sqrt{1 + \left( \frac{\omega}{\omega_2} \right)^4}} + \frac{K_L}{\sqrt{1 + \left( \frac{\omega}{\omega_1} \right)^4}} \right]$$

where,  $K_H = \left( 1 + \frac{R'_f}{R''} \right)$  and,  $K_L = \left( 1 + \frac{R''_f}{R} \right)$  and for Butterworth filters,  $K_H = K_L = 1.586$ .

The roll-off frequency response will be very smooth as shown.

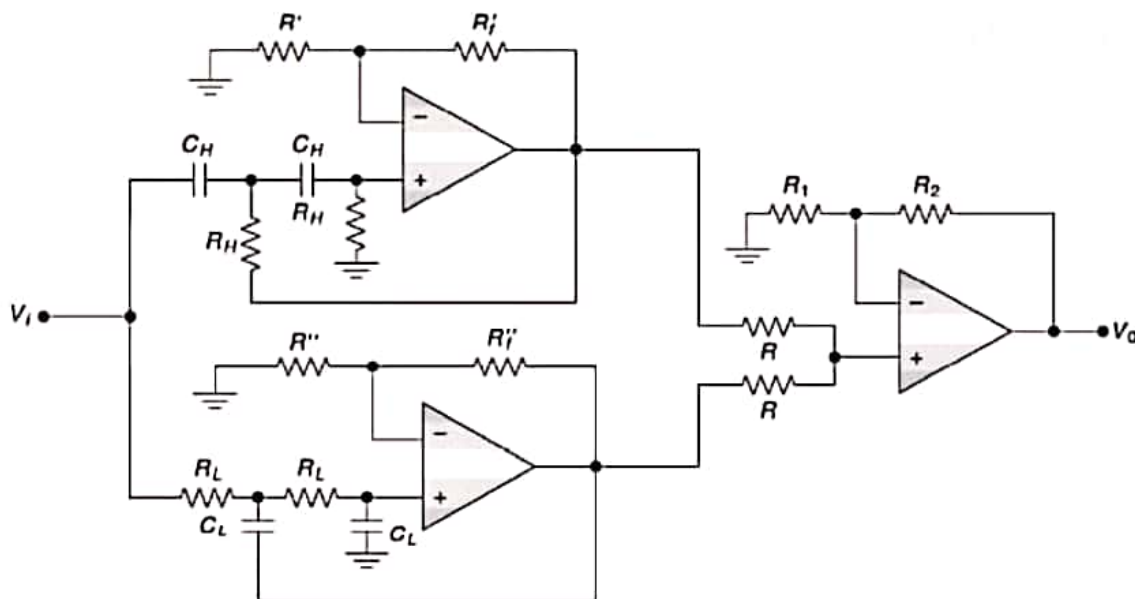

Figure 9.30 Second-order band-reject active filter circuit

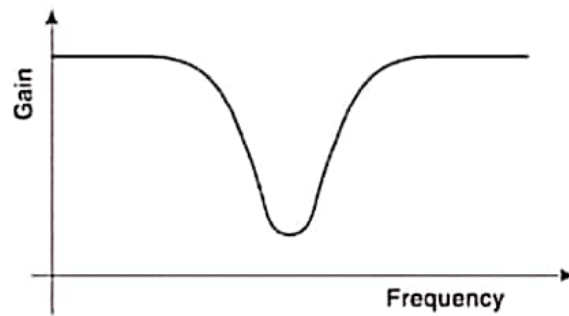

Figure 9.31 Frequency response of second order band-reject filter

### 9.11 ALL-PASS ACTIVE FILTER

This filter passes all frequency component of the input signal without attenuation and provides some phase shifts between the input and output signals.

The circuit of an active all-pass active filter with lagging output is shown in Figure 9.32.

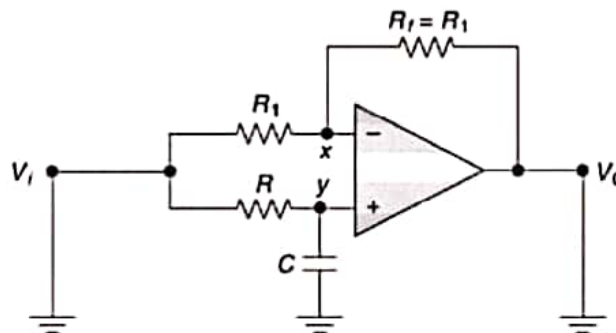

Figure 9.32 Circuit of an all-pass active filter with lagging output

For the circuit, by KCL at node  $x$ ,

$$\frac{V_x - V_i}{R_1} + \frac{V_x - V_0}{R_1} = 0 \Rightarrow V_x = \frac{V_i + V_0}{2} \quad (9.19)$$

By KCL at node  $y$ ,

$$\frac{V_y - V_i}{R} + \frac{V_y}{1/j\omega C} = 0 \Rightarrow V_y = \frac{V_i}{1 + j\omega RC} \quad (9.20)$$

Also, from Op-Amp property,

$$V_x = V_y$$

$$\Rightarrow \left( \frac{V_i + V_0}{2} \right) = \left( \frac{V_i}{1 + j\omega RC} \right)$$

$$\Rightarrow (V_i + V_0)(1 + j\omega RC) = 2V_i$$

$$\Rightarrow V_0(1 + j\omega RC) = V_i[2 - (1 + j\omega RC)] = V_i(1 - j\omega RC)$$

$$\therefore \frac{V_0}{V_i} = \frac{1 - j\omega RC}{1 + j\omega RC}$$

Thus, the amplitude of the gain,

$$\left| \frac{V_0}{V_i} \right| = 1 \quad \text{i.e., } |V_{\text{out}}| = |V_{\text{in}}| \text{ throughout the entire frequency range}$$

Also, the phase shift between the input and the output voltages is,

$$\phi = -2 \tan^{-1}(\omega RC) \quad \text{i.e., phase-shift is a function of frequency}$$

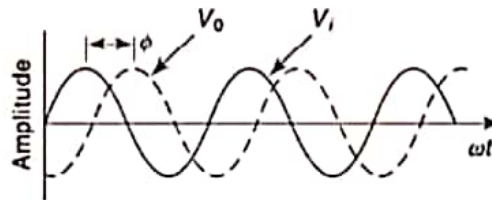

Figure 9.33 Characteristics of all-pass filter

By interchanging the positions of  $R$  and  $C$  in the circuit, the output can be made leading the input.

### MULTIPLE-CHOICE QUESTIONS

- 9.1 The two input terminals of an op-amp are labeled as  
 (a) high and low (b) positive and negative  
 (c) inverting and non-inverting (d) differential and non-differential
- 9.2 Consider the following statements for an ideal op-amp.  
 1. The differential voltage across the input terminals is zero.  
 2. The current into the input terminals is zero.  
 3. The current from the output terminals is zero.  
 4. The input resistance is zero.  
 5. The output resistance is zero.  
 Of these statements, those which are not true are  
 (a) 1 and 5 (b) 3 and 4 (c) 2 and 4 (d) 1 and 4
- 9.3 In a series resonant circuit, to obtain a low-pass characteristic, across which element should the output voltage be taken?  
 (a) Resistor (b) Inductor (c) Capacitor
- 9.4 In a series resonant circuit, to obtain a high-pass characteristic, across which element should the output voltage be taken?  
 (a) Resistor (b) Inductor (c) Capacitor



- 9.5 In a series resonant circuit, to obtain a band-pass characteristic, across which element should the output voltage be taken?  
 (a) Resistor (b) Inductor (c) Capacitor
- 9.6 A high-pass filter circuit is basically  
 (a) a differentiating circuit with low time constant.  
 (b) a differentiating circuit with large time constant.  
 (c) an integrating circuit with low time constant.  
 (d) an integrating circuit with large time constant.
- 9.7 The transfer function of an electrical low-pass RC network is  
 (a)  $\frac{RCs}{1+RCs}$  (b)  $\frac{1}{1+RCs}$  (c)  $\frac{RC}{1+RCs}$  (d)  $\frac{s}{1+RCs}$
- 9.8 For a high-pass RC circuit, when subjected to a unit step input voltage, the voltage across the capacitor will be  
 (a)  $1 - e^{-t/RC}$  (b)  $e^{-t/RC}$  (c)  $e^{t/RC}$  (d) 1
- 9.9 In the magnitude plot of a low-pass filter, at what frequency does the peak of the magnitude characteristic occur?  
 (a) At resonant frequency (b) Below resonant frequency  
 (c) Above resonant frequency (d) At any frequency.
- 9.10 In the magnitude plot of a high-pass filter, at what frequency does the peak of the magnitude characteristic occur?  
 (a) At resonant frequency (b) Below resonant frequency  
 (c) Above resonant frequency (d) At any frequency.
- 9.11 In the magnitude plot of a band-pass filter, at what frequency does the peak of the magnitude characteristic occur?  
 (a) At resonant frequency (b) Below resonant frequency  
 (c) Above resonant frequency (d) At any frequency.
- 9.12 If a filter is de-normalized to a higher frequency, which of the following occurs?  
 (a) Inductors increase in value while capacitors decrease.  
 (b) Inductors decrease in value while capacitors increase.  
 (c) Inductors and capacitors increase in value.  
 (d) Inductors and capacitors decrease in value.
- 9.13 The transfer function  $\frac{V_2(s)}{V_1(s)} = \frac{10s}{s^2 + 10s + 100}$  is for an active  
 (a) low pass filter (b) band pass filter (c) high pass filter (d) all pass filter.
- 9.14 The transfer function  $T(s) = \frac{s^2}{s^2 + as + b}$  belongs to an active  
 (a) low pass filter (b) high pass filter (c) band pass filter (d) band reject filter.
- 9.15 The voltage-ratio transfer function of an active filter is given by  $\frac{V_2(s)}{V_1(s)} = \frac{s^2 + \delta}{s^2 + \alpha s + \delta}$ . The circuit in question is a  
 (a) low pass filter (b) high pass filter (c) band pass filter (d) band reject filter.

9.16

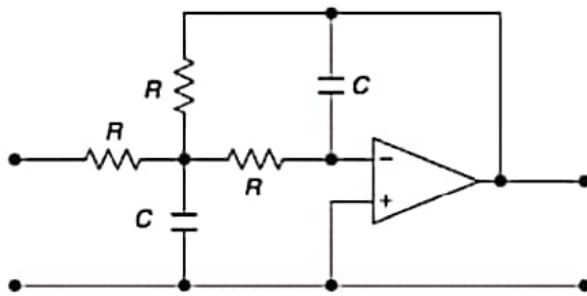

The transfer function of a second order LP filter shown in the figure is

(a)  $\frac{1}{R^2 C^2 s^2 + 3RCs + 1}$

(b)  $\frac{RCs}{R^2 C^2 s^2 + 3RCs + 1}$

(c)  $\frac{R^2 C^2 s^2 + 1}{R^2 C^2 s^2 + 3RCs + 1}$

(d)  $\frac{R^2 C^2 s^2}{R^2 C^2 s^2 + 3RCs + 1}$

9.17 An ideal filter should have

- (a) zero attenuation in the pass band
- (b) infinite attenuation in the pass band
- (c) zero attenuation in the attenuation band
- (d) none of these.

9.18 An *RLC* series circuit can act as

- (a) band-pass filter
- (b) band-stop filter
- (c) low-pass filter
- (d) both (a) and (b).

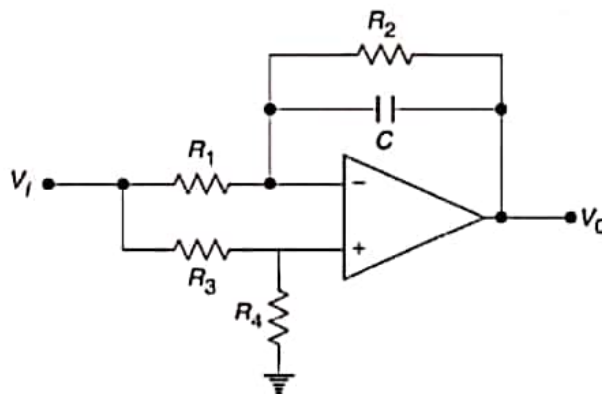
9.19 If  $R_1 = R_2 = R_A$  and  $R_3 = R_4 = R_B$ , the circuit acts as a/an

- (a) all pass filter
- (b) band pass filter
- (c) high pass filter
- (d) low pass filter

9.20 The output of the filter in 9.19 is given to the circuit shown in the figure.

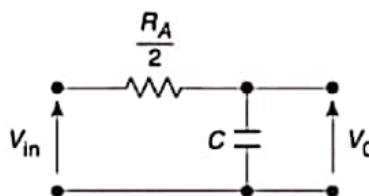

The gain vs frequency characteristic of the output ( $v_o$ ) will be

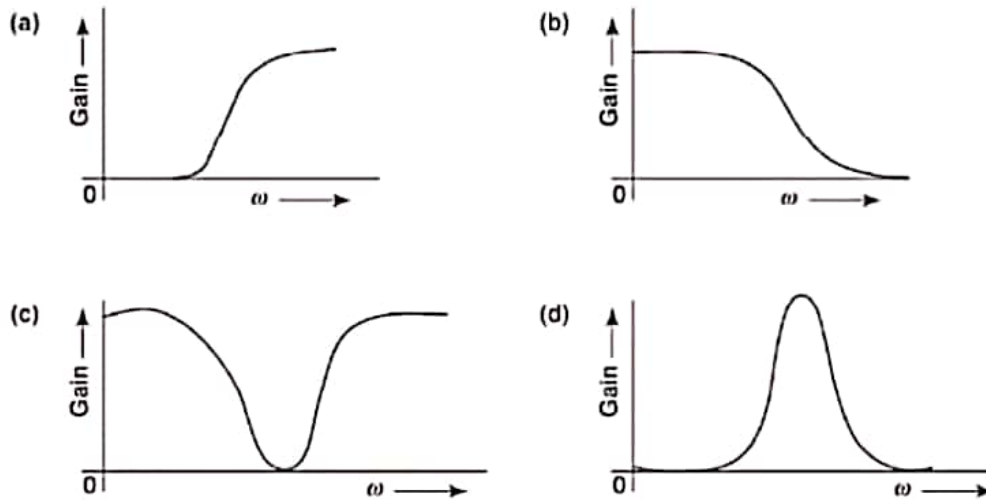

9.21 In active filter circuits, inductances are avoided mainly because they

- (a) are always associated with some resistance
- (b) are bulky and unstable for miniaturisation
- (c) are non-linear in nature
- (d) saturate quickly

9.22 The magnitude response of a normalized Butterworth low-pass filter is

- (a) linear starting with values of unity at zero frequency and 0.707 at the cut-off frequency
- (b) non-linear all through but with values of unity at zero frequency and 0.707 at the cut-off frequency
- (c) linear up to the cut-off frequency and non-linear thereafter
- (d) non-linear up to the cut-off frequency and linear thereafter

## EXERCISES

9.1 Design a second order low pass active filter having a cut-off frequency of 5 kHz.

$$[C = 0.03 \text{ mF}; R = 1 \text{ k}\Omega; R_1 = 10 \text{ k}\Omega; R_2 = 5.86 \text{ k}\Omega]$$

9.2 Design a second order band pass active filter that has a centre frequency of 1 kHz and a bandwidth of 100 Hz. Take the centre frequency gain to be 2.

$$[C_1 = C_2 = 0.02 \text{ mF}; R_1 = 40 \text{ k}\Omega; R_3 = 160 \text{ k}\Omega; R_2 = 400 \Omega]$$

9.3 Design a second order high pass Butterworth filter with a cut-off frequency of 200 Hz.

$$[C = 0.053 \text{ mF}; R = 1.5 \text{ k}\Omega; R_1 = 10 \text{ k}\Omega; R_2 = 5.86 \text{ k}\Omega]$$

9.4 Design a second order band pass active filter with a centre frequency gain  $A_0 = 50$ . Given:  $f_0 = 160 \text{ Hz}$  and  $Q = 10$ .

$$[\text{assuming } C_1 = C_2 = 0.1 \text{ mF}; R_1 = 2 \text{ k}\Omega; R_3 = 200 \text{ k}\Omega; R_2 = 667 \Omega]$$

---

**SHORT-ANSWER TYPE QUESTIONS**

---

- 9.1 (a) What is an operational-amplifier? State the characteristics of an op-amp.  
 (b) What is filter? Classify them.  
 (c) Discuss the advantages of an active filter over a passive filter.
- 9.2 (a) Briefly discuss the operating principle of an active low-pass filter and derive its gain-frequency characteristics. Explain the design procedure of a low-pass active filter.  
 (b) Briefly discuss the operating principle of an active high-pass filter and derive its gain-frequency characteristics. Explain the design procedure of a high-pass active filter.
- 9.3 (a) Define the following terms with reference to a band-pass active filter: -  
 (i) Bandwidth,  
 (ii) Cut-off frequency,  
 (iii) Quality factor.  
 (b) What are the different types of band-pass filters? Give the salient features and performance equations for the following filters: -  
 (i) Wide Band-Pass Active Filter,  
 (ii) Narrow Band-Pass Active Filter.
- 9.4 Define Notch-frequency. Explain the operational characteristics of an active Notch filter. Where are these filters used?

---

**ANSWERS TO MULTIPLE-CHOICE QUESTIONS**

---

- |          |          |          |          |          |          |          |
|----------|----------|----------|----------|----------|----------|----------|
| 9.1 (c)  | 9.2 (b)  | 9.3 (c)  | 9.4 (b)  | 9.5 (a)  | 9.6 (a)  | 9.7 (b)  |
| 9.8 (a)  | 9.9 (b)  | 9.10 (c) | 9.11 (a) | 9.12 (d) | 9.13 (c) | 9.14 (b) |
| 9.15 (c) | 9.16 (a) | 9.17 (a) | 9.18 (a) | 9.19 (c) | 9.20 (d) | 9.21 (b) |
| 9.22 (b) |          |          |          |          |          |          |