

# Overview of Optical Fiber communication

## 1. Historical Development

- Fiber optics deals with study of propagation of light through transparent dielectric waveguides. The fiber optics are used for transmission of data from point to point location. Fiber optic systems currently used most extensively as the transmission line between terrestrial hardwired systems.
- The carrier frequencies used in conventional systems had the limitations in handling the volume and rate of the data transmission. The greater the carrier frequency larger the available bandwidth and information carrying capacity.

### First generation

The first generation of light wave systems uses GaAs semiconductor laser and operating region was near  $0.8\ \mu\text{m}$ . Other specifications of this generation are as under:

- i) Bit rate : 45 Mb/s
- ii) Repeater spacing : 10 km

### Second generation

- i) Bit rate: 100 Mb/s to 1.7 Gb/s
- ii) Repeater spacing: 50 km
- iii) Operation wavelength:  $1.3\ \mu\text{m}$
- iv) Semiconductor: In GaAsP

### Third generation

- i) Bit rate : 10 Gb/s
- ii) Repeater spacing: 100 km
- iii) Operating wavelength:  $1.55\ \mu\text{m}$

### Fourth generation

Fourth generation uses WDM technique.

- i) Bit rate: 10 Tb/s
- ii) Repeater spacing:  $> 10,000\ \text{km}$
- iii) Operating wavelength:  $1.45\ \text{to}\ 1.62\ \mu\text{m}$

## Fifth generation

Fifth generation uses Roman amplification technique and optical solitons.

- i) Bit rate: 40 - 160 Gb/s
- ii) Repeater spacing: 24000 km - 35000 km
- iii) Operating wavelength: 1.53 to 1.57  $\mu\text{m}$

## Need of fiber optic communication

Fiber optic communication system has emerged as most important communication system. Compared to traditional system because of following requirements:

1. In long haul transmission system there is need of low loss transmission medium
2. There is need of compact and least weight transmitters and receivers.
3. There is need of increase dspan of transmission.
4. There is need of increased bit rate-distance product.

A fiber optic communication system fulfills these requirements, hence most widely accepted

## 2. General Optical Fiber Communication System.

Basic block diagram of optical fiber communication system consists of following important blocks.

1. Transmitter
2. Information channel
3. Receiver.

Fig. 1.2.1 shows block diagram of OFC system.

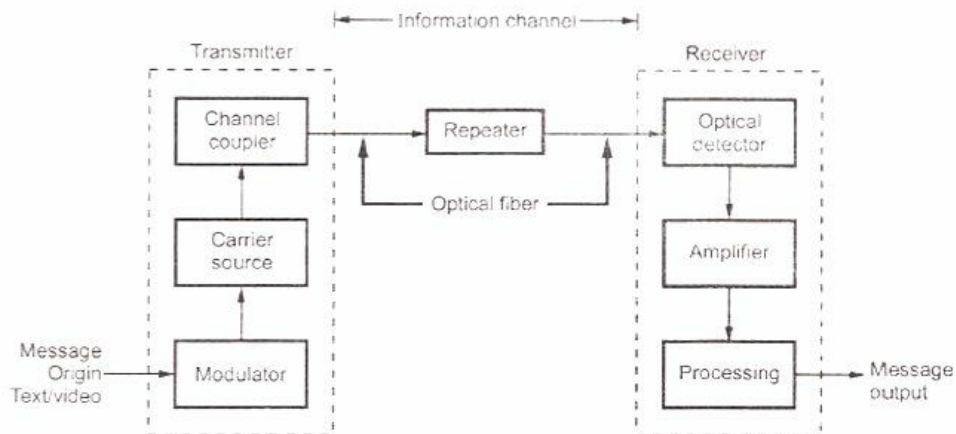

Fig. 1.2.1 Block diagram of OFC systems

## **Message origin**

Generally message origin is from a transducer that converts a non-electrical message into an electrical signal. Common examples include microphones for converting sound waves into currents and video (TV) cameras for converting images into current. For data transfer between computers, the message is already in electrical form.

## **Modulator**

The modulator has two main functions.

1. It converts the electrical message into the proper format.
2. It impresses this signal onto the wave generated by the carrier source.
3. Two distinct categories of modulation are used i.e. analog modulation and digital modulation.

## **Carrier source**

Carrier source generates the wave on which the information is transmitted. This wave is called the carrier. For fiber optic system, a laser diode (LD) or a light emitting diode (LED) is used. They can be called as optic oscillators; they provide stable, single frequency waves with sufficient power for long distance propagation.

## **Channel coupler**

Coupler feeds the power into the information channel. For an atmospheric optic system, the channel coupler is a lens used for collimating the light emitted by the source and directing this light towards the receiver. The coupler must efficiently transfer the modulated light beam from the source to the optic fiber. The channel coupler design is an important part of fiber system because of possibility of high losses.

## **Information channel**

The information channel is the path between the transmitter and receiver. In fiber optic communications, a glass or plastic fiber is the channel. Desirable characteristics of the information channel include low attenuation and large light acceptance cone angle. Optical amplifiers boost the power levels of weak signals. Amplifiers are needed in very long links to provide sufficient power to the receiver. Repeaters can be used only for digital systems. They convert weak and distorted optical signals to electrical ones and then regenerate the original digital pulse trains for further transmission.

Another important property of the information channel is the propagation time of the waves travelling along it. A signal propagating along a fiber normally contains a range of optic frequencies and divides its power along several ray paths. This results in a distortion of the propagating signal. In a digital system, this distortion appears as a spreading and deforming of the pulses. The spreading is so great that adjacent pulses begin to overlap and become unrecognizable as separate bits of information.

### **Optical detector**

The information being transmitted is detector. In the fiber system the optic wave is converted into an electric current by a photo detector. The current developed by the detector is proportional to the power in the incident optic wave. Detector output current contains the transmitted information. This detector output is then filtered to remove the constant bias and then amplified.

The important properties of photo detectors are small size, economy, long life, low power consumption, high sensitivity to optic signals and fast response to quick variations in the optic power.

### **Signal processing**

Signal processing includes filtering, amplification. Proper filtering maximizes the ratio of signal to unwanted power. For a digital system decision circuit is an additional block. The bit error rate (BER) should be very small for quality communications.

### **Message output**

The electrical forms of the message emerging from the signal processor are transformed into a sound wave or visual image. Sometimes these signals are directly usable when computers or other machines are connected through a fiber system.

## **3. Advantages of Optical Fiber Communications**

### **1. Wide bandwidth**

The light wave occupies the frequency range between  $2 \times 10^{12}$  Hz to  $3.7 \times 10^{12}$  Hz. Thus the information carrying capability of fiber optic cables is much higher.

### **2. Low losses**

Fiber optic cables offers very less signal attenuation over long distances. Typically it is less than 1 dB/km. This enables longer distance between repeaters.

### **3. Immune to cross talk**

Fiber optic cables have very high immunity to electrical and magnetic field. Since fiber optic cables are non-conductors of electricity hence they do not produce magnetic field. Thus fiber optic cables are immune to cross talk between cables caused by magnetic induction.

### **4. Interference immune**

Fiber optic cable immune to conductive and radiative interferences caused by electrical noise sources such as lighting, electric motors, fluorescent lights.

### **5. Light weight**

As fiber cables are made of silica glass or plastic which is much lighter than copper or aluminum cables. Light weight fiber cables are cheaper to transport.

### **6. Small size**

7. The diameter of fiber is much smaller compared to other cables, therefore fiber cable is small in size, requires less storage space.

### **8. More strength**

Fiber cables are stronger and rugged hence can support more weight.

### **9. Security**

Fiber cables are more secure than other cables. It is almost impossible to tap into a fiber cable as they do not radiate signals. No ground loops exist between optical fibers hence they are more secure.

### **10. Long distance transmission**

Because of less attenuation transmission at a longer distance is possible.

### **11. Environment immune**

Fiber cables are more immune to environmental extremes. They can operate over large temperature variations. Also they are not affected by corrosive liquids and gases.

### **12. Sage and easy installation**

Fiber cables are safer and easier to install and maintain. They are non-conductors hence there is no shock hazards as no current or voltage is associated with them. Their small size and light weight feature makes installation easier.

### **13. Less cost**

Cost of fiber optic system is less compared to any other system.

## **4. Disadvantages of Optical Fiber Communications**

### **1. High initial cost**

The initial cost of installation or setting up cost is very high compared to all other system.

### **2. Maintenance and repairing cost**

The maintenance and repairing of fiber optic systems is not only difficult but expensive also.

### **3. Jointing and test procedures**

Since optical fibers are of very small size. The fiber joining process is very costly and requires skilled manpower.

### **4. Tensile stress**

Optical fibers are more susceptible to buckling, bending and tensile stress than copper cables. This leads to restricted practice to use optical fiber technology to premises and floor backbones with a few interfaces to the copper cables.

### **5. Short links**

Even though optical fiber cables are inexpensive, it is still not cost effective to replace every small conventional connector (e.g. between computers and peripherals), as the price of optoelectronic transducers are very high.

### **6. Fiber losses**

The amount of optical fiber available to the photo detector at the end of fiber length depends on various fiber losses such as scattering, dispersion, attenuation and reflection.

## **5. Applications of Optical Fiber Communications**

Applications of optical fiber communications include telecommunications, data communications, video control and protection switching, sensors and power applications.

### **1. Telephone networks**

Optical waveguide has low attenuation, high transmission bandwidth compared to copper lines; therefore numbers of long haul co-axial trunks links between telephone exchanges are being replaced by optical fiber links.

### **2. Urban broadband service networks**

- Optical waveguide provides much larger bandwidth than co-axial cable, also the number of repeaters required is reduced considerably.



- Modern suburban communications involves videotext, videoconferencing Video telephony Switched broadband communication network. All these can be supplied over a single fiber optic link. Fiber optic cables is the solution to many of today's high speed, high bandwidth data communication problems and will continue to play a large role in future telecom and data-com networks.

## 6. Optical Fiber Waveguides

In free space light travels at its maximum possible speed i.e.  $3 \times 10^8$  m/s or 186 x 10<sup>3</sup> miles/sec. When light travels through a material it exhibits certain behavior explained by laws of reflection, refraction.

### a. Electromagnetic Spectrum

- The radio waves and light are electromagnetic waves. The rate at which they alternate in polarity is called their frequency (f) measured in hertz (Hz). The speed of electromagnetic wave (c) in free space is approximately  $3 \times 10^8$  m/sec. The distance travelled during each cycle is called as wavelength ( $\lambda$ )

$$\text{Wavelength } (\lambda) = \frac{\text{Speed of light}}{\text{Frequency}} = \frac{c}{f}$$

- In fiber optics, it is more convenient to use the wavelength of light instead of the frequency with light frequencies, wavelength is often stated in microns or nanometers  
1 micron ( $\mu$ ) = 1 Micrometre ( $1 \times 10^{-6}$ )  
1 nano (n) =  $10^{-9}$  metre
- Fig. 1.6.1 shows electromagnetic frequency spectrum.

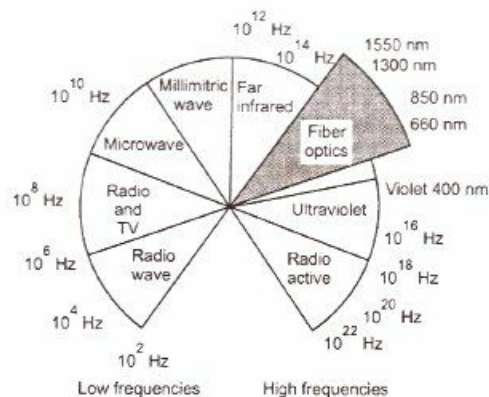

Fig. 1.6.1 Electromagnetic spectrum

Fiber optics uses visible and infrared light. Infrared light covers a fairly wide range of wavelengths and is generally used for all fiber optic communications. Visible light is normally used for very short range transmission using a plastic fiber.

## 7. Ray Transmission Theory

Before studying how the light actually propagates through the fiber, laws governing the nature of light must be studied. These were called as laws of optics (Ray theory). There is a misconception that light always travels at the same speed. This fact is simply not true. The speed of light depends upon the material or medium through which it is moving. In free space light travels at its maximum possible speed i.e.  $3 \times 10^8$  m/s or  $186 \times 10^3$  miles/sec. When light travels through a material it exhibits certain behavior explained by laws of reflection, refraction.

### b. Reflection

The law of reflection states that, when a light ray is incident upon a reflective surface at some incident angle  $\phi_1$  from imaginary perpendicular normal, the ray will be reflected from the surface at some angle  $\phi_2$  from normal which is equal to the angle of incidence. Fig. 1.6.2 shows law of reflection.

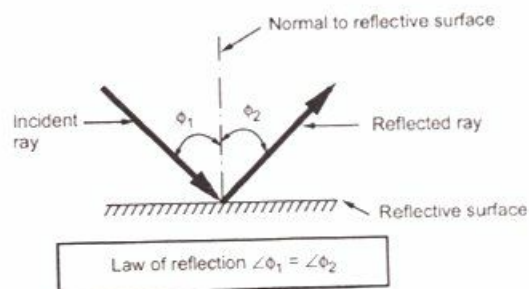

Fig. 1.6.2 Reflection

### c. Refraction

Refraction occurs when light ray passes from one medium to another i.e. the light ray changes its direction at interface. Refraction occurs whenever density of medium changes. E.g. refraction occurs at air and water interface, the straw in a glass of water will appear as it is bent.

The refraction can also be observed at air and glass interface.

- When a wave passes through a less dense medium to a denser medium, the wave is refracted (bent) towards the normal. Fig. 1.6.3 shows the refraction phenomena.
- The refraction (bending) takes place because light travels at different speeds in different mediums. The speed of light in free space is higher than in water or glass.



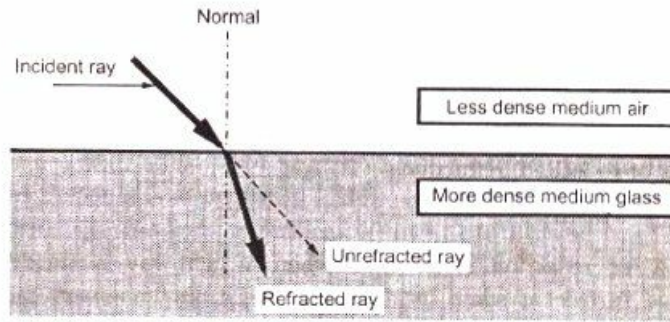

Fig. 1.6.3 Refraction

#### d. Refractive Index

- The amount of refraction or bending that occurs at the interface of two materials of different densities is usually expressed as refractive index of two materials. Refractive index is also known as index of refraction and is denoted by  $n$ .
- Based on material density, the refractive index is expressed as the ratio of the velocity of light in free space to the velocity of light of the dielectric material (substance).

$$\text{Refractive index } n = \frac{\text{Speed of light in air}}{\text{Speed of light in medium}} = \frac{c}{v}$$

The refractive index for vacuum and air is 1.0 for water it is 1.3 and for glass refractive index is 1.5.

#### e. Snell's Law

- Snell's law states how light ray reacts when it meets the interface of two media having different indexes of refraction.
- Let the two medias have refractive indexes  $n_1$  and  $n_2$  where  $n_1 > n_2$ .
- $\phi_1$  and  $\phi_2$  be the angles of incidence and angle of refraction respectively. Then according to Snell's law, a relationship exists between the refractive index of both materials given by,

$$n_1 \sin \phi_1 = n_2 \sin \phi_2$$

- A refractive index model for Snell's law is shown in Fig. 1.6.4.

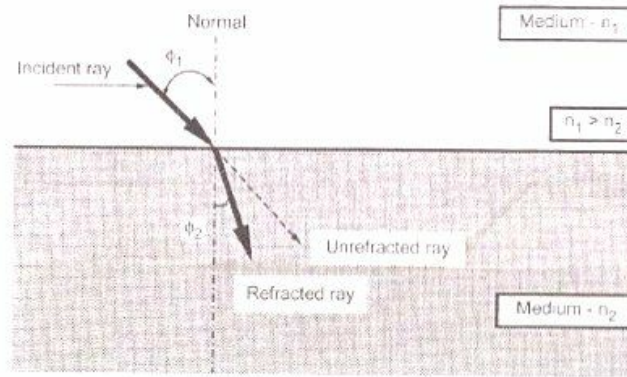

Fig. 1.6.4 Refractive model for Snell's law

- The refracted wave will be towards the normal when  $n_1 < n_2$  and will away from it then  $n_1 > n_2$ .
- Equation can be written as,

$$\frac{n_1}{n_2} = \frac{\sin \phi_2}{\sin \phi_1}$$

- This equation shows that the ratio of refractive index of two mediums is inversely proportional to the refractive and incident angles. As refractive index

$$n_1 = \frac{c}{v_1}$$

- substituting these values in equation

$$n_2 = \frac{c}{v_2}$$

$$\frac{c/v_1}{c/v_2} = \frac{\sin \phi_2}{\sin \phi_1}$$

$$\frac{v_2}{v_1} = \frac{\sin \phi_2}{\sin \phi_1}$$

#### f. Critical Angle

- When the angle of incidence ( $\phi_1$ ) is progressively increased, there will be progressive increase of refractive angle ( $\phi_2$ ). At some condition ( $\phi_1$ ) the refractive angle ( $\phi_2$ ) becomes  $90^\circ$  to the normal. When this happens the refracted light ray travels along

the interface. The angle of incidence ( $\phi_1$ ) at the point at which the refractive angle ( $\phi_2$ ) becomes 90 degree is called the critical angle. It is denoted by  $\phi_c$ .

- The critical angle is defined as the minimum angle of incidence ( $\phi_1$ ) at which the ray strikes the interface of two media and causes an angle of refraction ( $\phi_2$ ) equal to 90o.

Fig 1.6.5 shows critical angle refraction

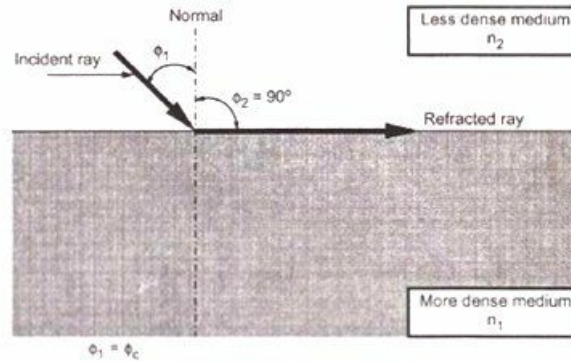

Fig. 1.6.5 Critical angle

Hence at critical angle  $\phi_1 = \phi_c$  and  $\phi_2 = 90^\circ$ . Using Snell's law:  $n_1 \sin \phi_1 = n_2 \sin \phi_2$

$$\sin \phi_c = \frac{n_2}{n_1} \sin 90^\circ$$

$$\sin 90^\circ = 1$$

$$\sin \phi_c = \frac{n_2}{n_1}$$

$$\text{Critical angle } \phi_c = \sin^{-1} \left( \frac{n_2}{n_1} \right)$$

The actual value of critical angle is dependent upon combination of materials present on each side of boundary.

### g. Total Internal Reflection (TIR)

- When the incident angle is increase beyond the critical angle, the light ray does not pass through the interface into the other medium. This gives the effect of mirror exist at the interface with no possibility of light escaping outside the medium. In this condition angle of reflection ( $\phi_2$ ) is equal to angle of incidence ( $\phi_1$ ). This action is called as Total Internal Reflection (TIR) of the beam. It is TIR that leads to the

propagation of waves within fiber-cable medium. TIR can be observed only in materials in which the velocity of light is less than in air.

- The two conditions necessary for TIR to occur are:
  1. The refractive index of first medium must be greater than the refractive index of second one.
  2. The angle of incidence must be greater than (or equal to) the critical angle.

#### h. Acceptance Angle

Applying Snell's law to external incidence angle.

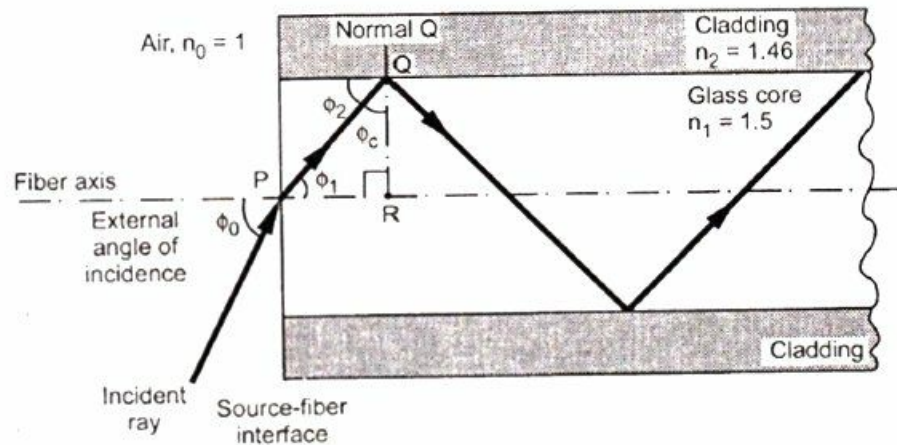

**Fig. 1.6.8 Ray propagation by TIR**

$$n_0 \sin \phi_0 = n_1 \sin \phi_1$$

But  $\phi_1 = (90 - \phi_c)$

$$\sin \phi_1 = \sin (90 - \phi_c) = \cos \phi_c$$

Substituting  $\sin \phi_1$  in above equation.

$$n_0 \sin \phi_0 = n_1 \cos \phi_c$$

$$\sin \phi_0 = \frac{n_1}{n_0} \cos \phi_c$$

Applying Pythagorean Theorem to  $\Delta PQR$ .

$$\cos \phi_c = \frac{\sqrt{n_1^2 - n_2^2}}{n_1}$$



$$\sin \phi_0 = \frac{n_1}{n_0} \left[ \frac{\sqrt{n_1^2 - n_2^2}}{n_1} \right]$$

$$\sin \phi_0 = \left[ \frac{\sqrt{n_1^2 - n_2^2}}{n_0} \right]$$

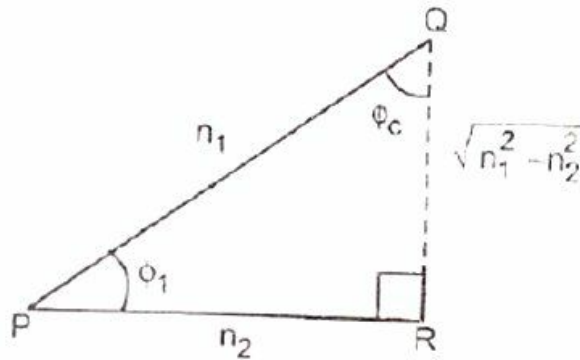

Fig. 1.6.9

$$\phi_0 = \sin^{-1} \left[ \frac{\sqrt{n_1^2 - n_2^2}}{n_0} \right]$$

The maximum value of external incidence angle for which light will propagate in the fiber.

$$\phi_{0(\max)} = \sin^{-1} \left[ \frac{\sqrt{n_1^2 - n_2^2}}{n_0} \right]$$

When the light rays enters the fibers from an air medium  $n_0 = 1$ . Then above equation reduces to,

$$\phi_{0(\max)} = \sin^{-1} \left( \sqrt{n_1^2 - n_2^2} \right)$$

The angle  $\phi_0$  is called as acceptance angle and  $\phi_{0\max}$  defines the maximum angle in which the light ray may incident on fiber to propagate down the fiber.

### i. Acceptance Cone



Rotating the acceptance angle  $\phi_{\text{max}}$  around the fiber axis, a cone shaped pattern is obtained, it is called as acceptance cone of the fiber input. Fig 1.6.10 shows formation of acceptance cone of a fiber cable.

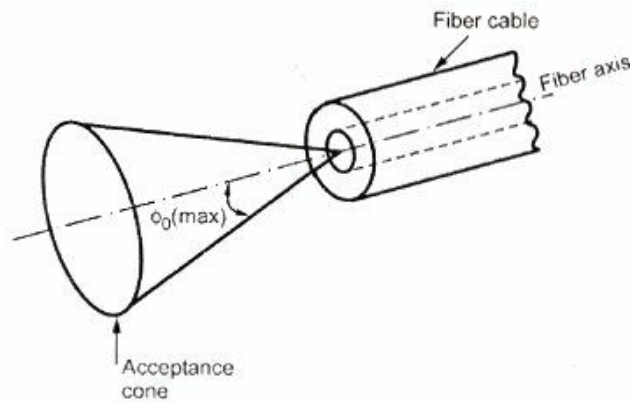

**Fig. 1.6.10 Acceptance cone of a fiber cable**

The Cone of acceptance is the angle within which the light is accepted into the core and is able to travel along the fiber. The launching of light wave becomes easier for large acceptance cone.

- The angle is measured from the axis of the positive cone so the total angle of convergence is actually twice the stated value.

#### **j. Numerical Aperture (NA)**

- The numerical aperture (NA) of a fiber is a figure of merit which represents its light gathering capability. Larger the numerical aperture, the greater the amount of light accepted by fiber. The acceptance angle also determines how much light is able to be enter the fiber and hence there is relation between the numerical aperture and the cone of acceptance.

$$\text{Numerical aperture (NA)} = \sin \phi_{\text{max}}$$

$$NA = \frac{\sqrt{n_1^2 - n_2^2}}{n_0}$$

$$\text{For air } n_0 = 1$$

$$NA = \sqrt{n_1^2 - n_2^2}$$

$$NA = \sqrt{n_{\text{core}}^2 - n_{\text{cladding}}^2}$$

Hence acceptance angle =  $\sin^{-1} NA$

By the formula of NA note that the numerical aperture is effectively dependent only on refractive indices of core and cladding material. NA is not a function of fiber dimension.

- The index difference ( $\Delta$ ) and the numerical aperture (NA) are related to the core and cladding indices:

$$\Delta = \frac{(n_1 - n_2)^2}{n_1^2}$$

$$\Delta = \frac{NA^2}{2n_1^2}$$

Also

$$NA = \sqrt{n_1^2 - n_2^2}$$

$$NA = (n_1^2 - n_2^2)^{1/2}$$

$$NA = n_1 (2\Delta)^{1/2}$$

**Example 1.6.1:** A light ray is incident from medium-1 to medium-2. If the refractive indices of medium-1 and medium-2 are 1.5 and 1.36 respectively then determine the angle of refraction for an angle of incidence of 30°.

**Solution:** Medium-1,  $n_1 = 1.5$

Medium-2,  $n_2 = 1.36$

Angle of incidence  $\phi_1 = 30^\circ$ .

Angle of incident  $\phi_2 = ?$

$$\text{Snell's law: } n_1 \sin \phi_1 = n_2 \sin \phi_2$$

$$1.5 \sin 30^\circ = 1.36 \sin \phi_2$$

$$\sin \phi_2 = \frac{1.5}{1.36} \sin 30^\circ$$

$$\sin \phi_2 = 0.55147$$

$$\phi_2 = 33.46^\circ$$

Angle of refraction 33.46 degrees from normal.

## 8. Optical Fiver as Waveguide

An optical fiber is a cylindrical dielectric waveguide capable of conveying electromagnetic waves at optical frequencies. The electromagnetic energy is in the form of the light and propagates along the axis of the fiber. The structural of the fiver determines the transmission characteristics.

- The propagation of light along the waveguide is decided by the modes of the waveguides, here mode means path. Each mode has distict pattern of electric and magnetic field distributions along the fiber length. Only few modes can satisfy the homogeneous wave equation in the fiver also the boundary condition a waveguide surfaces. When there is only one path for light to follow then it is called as single mode propagation. When there is more than one path then it is called as multimode propagation. Single fiber structure
- A single fiber structure is shown in Fig. 1.6.6. It consists of a solid dielectric cylinder with radius 'a'. This cylinder is called as core of fiber. The core is surrounded by dielectric, called cladding. The index of refraction of core (glass fiber) is slightly greater than the index of refraction of cladding. If refractive index of core (glass fiver) =  $n_1$  and refractive index of cladding =  $n_2$  then  $n_1 > n_2$ .



**Fig. 1.6.6 Single optical fiber structure**

## 9. Modes of Fiber

Fiber cables cal also be classified as per their mode. Light rays propagate as an electromagnetic wave along the fiber. The two components, the electric field and the magnetic field form patterns across the fiber. These patterns are called modes of transmission. The mode of a fiber refers to the number of paths for the light rays within the cable. According to modes optic fibers can be classified into two types.

1. Single mode fiber

## 2. Multimode fiber.

- Multimode fiber was the first fiber type to be manufactured and commercialized. The term multimode simply refers to the fact that numerous modes (light rays) are carried simultaneously through the waveguide. Multimode fiber has a much larger diameter, compared to single mode fiber, this allows large number of modes.

- Single mode fiber allows propagation to light ray by only one path. Single mode fibers are best at retaining the fidelity of each light pulse over longer distance also they do not exhibit dispersion caused by multiple modes. Thus more information can be transmitted per unit of time. This gives single mode fiber higher bandwidth compared to multimode fiber.

- Some disadvantages of single mode fiber are smaller core diameter makes coupling light into the core more difficult. Precision required for single mode connectors and splices are more demanding.

### **Fiber Profiles**

- A fiber is characterized by its profile and by its core and cladding diameters.
- One way of classifying the fiber cables is according to the index profile at fiber. The index profile is a graphical representation of value of refractive index across the core diameter.

- There are two basic types of index profiles.

1. Step index fiber.
2. Graded index fiber.

### **Step Index (SI) Fiber**

The step index (SI) fiber is a cylindrical waveguide core with central or inner core has a uniform refractive index of  $n_1$  and the core is surrounded by outer cladding with uniform refractive index of  $n_2$ . The cladding refractive index ( $n_2$ ) is less than the core refractive index ( $n_1$ ). But there is an abrupt change in the refractive index at the core cladding interface. Refractive index profile of step indexed optical fiber is shown in Fig. 1.6.13. The refractive index is plotted on horizontal axis and radial distance from the core is plotted on vertical axis.



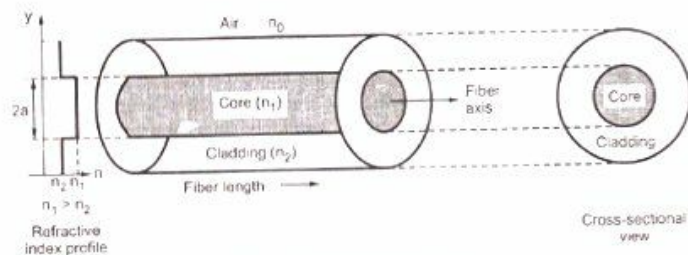

Fig. 1.6.13 Step index fiber

The propagation of light wave within the core of step index fiber takes the path of meridional ray i.e. ray follows a zig-zag path of straight line segments. The core typically has diameter of 50-80  $\mu\text{m}$  and the cladding has a diameter of 125  $\mu\text{m}$ .

- The refractive index profile is defined as –

$$n(r) = \begin{cases} n_1 & \text{when } r < a \text{ (core)} \\ n_2 & \text{when } r \geq a \text{ (cladding)} \end{cases}$$

### Graded Index (GRIN) Fiber

- The graded index fiber has a core made from many layers of glass.
- In the graded index (GRIN) fiber the refractive index is not uniform within the core, it is highest at the center and decreases smoothly and continuously with distance towards the cladding. The refractive index profile across the core takes the parabolic nature. Fig. 1.6.14 shows refractive index profile of graded index fiber .

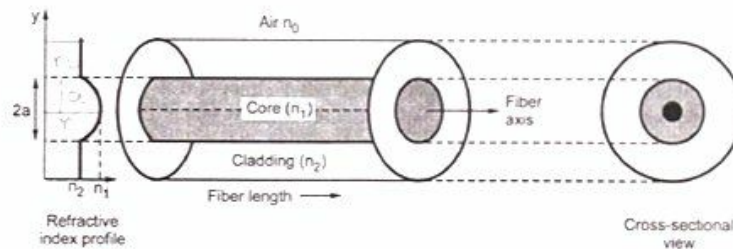

Fig. 1.6.14 Graded index fiber

- In graded index fiber the light waves are bent by refraction towards the core axis and they follow the curved path down the fiber length. This results because of change in refractive index as moved away from the center of the core.
- A graded index fiber has lower coupling efficiency and higher bandwidth than the step index fiber. It is available in 50/125 and 62.5/125 sizes. The 50/125 fiber has been optimized for long haul applications and has a smaller NA and higher bandwidth. 62.5/125 fiber is optimized for LAN applications which is costing 25% more than the 50/125 fiber cable.



- The refractive index variation in the core is given by relationship

$$n(r) = \begin{cases} n_1 \left(1 - 2\Delta \left(\frac{r}{a}\right)^\alpha\right) & \text{when } r \leq a \text{ (core)} \\ n_1(1 - 2\Delta)^{\frac{1}{\alpha}} \approx n_2 & \text{when } r \geq a \text{ (cladding)} \end{cases}$$

Where,

r = Radial distance from fiber axis

a = Core radius

n1 = Refractive index of core

n2 = Refractive index of cladding

$\alpha$  = Shape of index profile.

### Comparison of Step Index and Graded Index Fiber

Sr. No.	Parameter	Step index fiber	Graded index fiber
1.	Data rate	Slow.	Higher
2.	Coupling efficiency	Coupling efficiency with fiber is higher.	Lower coupling efficiency.
3.	Ray path	By total internal reflection.	Light ray travels in oscillatory fashion.
4.	Index variation	$\Delta = \frac{n_1 - n_2}{n_1}$	$\Delta = \frac{n_1^2 - n_2^2}{2n_1^2}$
5.	Numerical aperture	NA remains same.	Changes continuously with distance from fiber axis.
6.	Material used	Normally plastic or glass is preferred.	Only glass is preferred.
7.	Bandwidth efficiency	10 – 20 MHz km	1 GHz km
8.	Pulse spreading	Pulse spreading by fiber length is more.	Pulse spreading is less
9.	Attenuation of light	Less typically 0.34 dB km at 1.3 $\mu\text{m}$ .	More 0.6 to 1 dB km at 1.3 $\mu\text{m}$ .
10.	Typical light source	LED.	LED, Lasers.
11.	Applications	Subscriber local network communication.	Local and wide area networks.

### Optic Fiber Configurations

Depending on the refractive index profile of fiber and modes of fiber there exist three types of optical fiber configurations. These optic-fiber configurations are -

- Single mode step index fiber.

- Multimode step index fiber.
- Multimode graded index fiber.

### Single mode Step index Fiber

• In single mode step index fiber has a central core that is sufficiently small so that there is essentially only one path for light ray through the cable. The light ray is propagated in the fiber through reflection. Typical core sizes are 2 to 15  $\mu\text{m}$ . Single mode fiber is also known as fundamental or mono mode fiber.

- Fig. 1.6.16 shows single mode fiber.

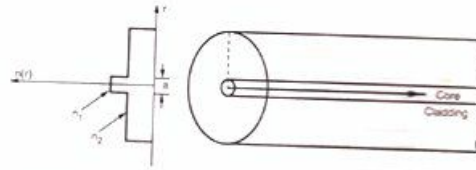

Fig. 1.6.16 The refractive index profile and ray transmission in single mode step index fiber.

• Single mode fiber will permit only one mode to propagate and does not suffer from mode delay differences. These are primarily developed for the 1300 nm window but they can be also be used effectively with time division multiple (TDM) and wavelength division multiplex (WDM) systems operating in 1550 nm wavelength region.

• The core fiber of a single mode fiber is very narrow compared to the wavelength of light being used. Therefore, only a single path exists through the cable core through, which light can travel. Usually, 20 percent of the light in a single mode cable actually travels down the cladding and the effective diameter of the cable is a blend of single mode core and degree to which the cladding carries light. This is referred to as the 'mode field diameter', which is larger than physical diameter of the core depending on the refractive indices of the core and cladding.

• The disadvantage of this type of cable is that because of extremely small size interconnection of cables and interfacing with source is difficult. Another disadvantage of single mode fibers is that as the refractive index of glass decreases with optical wavelength, the light velocity will also be wavelength dependent. Thus the light from an optical transmitter will have definite spectral width.

### Multimode step Index Fiber

- Multimode step index fiber is more widely used type. It is easy to manufacture. Its core diameter is 50 to 1000  $\mu\text{m}$  i.e. large aperture and allows more light to enter the cable. The light rays are propagated down the core in zig-zag manner. There are many paths that a light ray may follow during the propagation.

- The light ray is propagated using the principle of total internal reflection (TIR). Since the core index of refraction is higher than the cladding index of refraction, the light enters at less than critical angle is guided along the fiber.

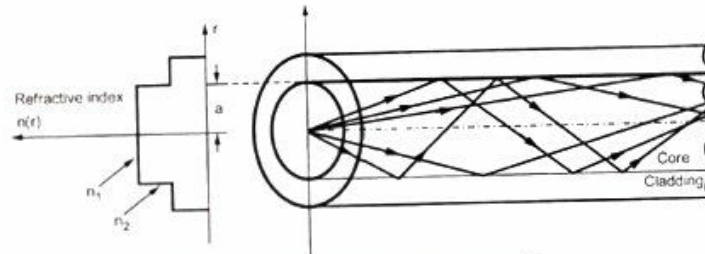

Fig. 1.6.17 TIR in multimode step index fiber

- Light rays passing through the fiber are continuously reflected off the glass cladding towards the centre of the core at different angles and lengths, limiting overall bandwidth.

- The disadvantage of multimode step index fibers is that the different optical lengths caused by various angles at which light is propagated relative to the core, causes the transmission bandwidth to be fairly small. Because of these limitations, multimode step index fiber is typically only used in applications requiring distances of less than 1 km.

### Multimode Graded Index Fiber

- The core size of multimode graded index fiber cable is varying from 50 to 100  $\mu\text{m}$  range. The light ray is propagated through the refraction. The light ray enters the fiber at many different angles. As the light propagates across the core toward the center it is intersecting a less dense to more dense medium. Therefore the light rays are being constantly being refracted and ray is bending continuously. This cable is mostly used for long distance communication.

- Fig 1.6.18 shows multimode graded index fiber.



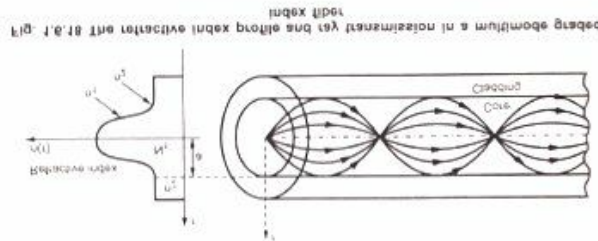

- The light rays no longer follow straight lines, they follow a serpentine path being gradually bent back towards the center by the continuously declining refractive index. The modes travelling in a straight line are in a higher refractive index so they travel slower than the serpentine modes. This reduces the arrival time disparity because all modes arrive at about the same time.

- Fig 1.6.19 shows the light trajectory in detail. It is seen that light rays running close to the fiber axis with shorter path length, will have a lower velocity because they pass through a region with a high refractive index.

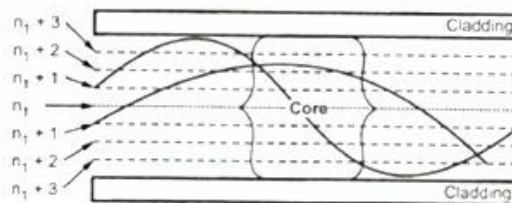

Fig. 1.6.19 Light trajectories in a graded index fiber

Rays on core edges offers reduced refractive index, hence travel more faster than axial rays and cause the light components to take same amount of time to travel the length of fiber, thus minimizing dispersion losses. Each path at a different angle is termed as 'transmission mode' and the NA of graded index fiber is defined as the maximum value of acceptance angle at the fiber axis.

- Typical attenuation coefficients of graded index fibers at 850 nm are 2.5 to 3 dB/km, while at 1300 nm they are 1.0 to 1.5 dB/km.
- The main advantages of graded index fiber are:
  1. Reduced refractive index at the centre of core.
  2. Comparatively cheap to produce.

## 10.Mode Theory for Cylindrical Waveguide

To analyze the optical fiber propagation mechanism within a fiber, Maxwell equations are to solve subject to the cylindrical boundary conditions at core-cladding interface. The

core-cladding boundary conditions lead to coupling of electric and magnetic field components resulting in hybrid modes. Hence the analysis of optical waveguide is more complex than metallic hollow waveguide analysis.

- Depending on the large E-field, the hybrid modes are HE or EH modes. The two lowest order does are HE<sub>11</sub> and TE<sub>01</sub>.

## 11. Overview of Modes

- The order states the number of field zeros across the guide. The electric fields are not completely confined within the core i.e. they do not go to zero at core-cladding interface and extends into the cladding. The low order mode confines the electric field near the axis of the fiber core and there is less penetration into the cladding. While the high order mode distribute the field towards the edge of the core fiber and penetrations into the cladding. Therefore cladding modes also appear resulting in power loss. In leaky modes the fields are confined partially in the fiber core attenuated as they propagate along the fiber length due to radiation and tunnel effect.

- Therefore in order to mode remain guided, the propagation factor  $\beta$  must satisfy the Condition

$$n_2 k < \beta < n_1 k$$

Where,  $n_1$  = Refractive index of fiber core

$n_2$  = Refractive index of cladding

$k$  = Propagation constant =  $2\pi / \lambda$

- The cladding is used to prevent scattering loss that results from core material discontinuities. Cladding also improves the mechanical strength of fiber core and reduces surface contamination. Plastic cladding is commonly used. Materials used for fabrication of optical fibers are silicon dioxide (SiO<sub>2</sub>), boric oxide-silica.

### Summary of Key Modal Concepts

- Normalized frequency variable,  $V$  is defined as

$$V = \frac{2\pi a (n_1^2 - n_2^2)^{1/2}}{\lambda}$$



Where,

$a$  = Core radius

$\lambda$  = Free space wavelength

$$V = \frac{2\pi a}{\lambda} NA$$

$$\text{Since } (n_1^2 - n_2^2)^{1/2} = NA$$

The total number of modes in a multimode fiber is given by

$$M = \frac{1}{2} \left( \frac{2\pi a}{\lambda} \right)^2 (n_1^2 - n_2^2)$$

$$M = \frac{1}{2} \left[ \frac{2\pi a}{\lambda} NA \right]^2 = \frac{[V]^2}{2}$$

$$M = \frac{1}{2} \left[ \frac{\pi d}{\lambda} \cdot NA \right]^2$$

**Example 1.7.1 :** Calculate the number of modes of an optical fiber having diameter of 50  $\mu\text{m}$ ,  $n_1 = 1.48$ ,  $n_2 = 1.46$  and  $\lambda = 0.82 \mu\text{m}$ .

**Solution:**  $d = 50 \mu\text{m}$

$n_1 = 1.48$

$n_2 = 1.46$

$\lambda = 0.82 \mu\text{m}$

$$NA = (n_1^2 - n_2^2)^{1/2}$$

Number of modes is given by,

$$M = \frac{V^2}{2}$$

$$M = \frac{(76.79)^2}{2} = 2871.50$$

**Example 1.7.4:** A step index multimode fiber with a numerical aperture of a 0.20 supports approximately 1000 modes at an 850 nm wavelength.

- i) What is the diameter of its core?
- ii) How many modes does the fiber support at 1320 nm?
- iii) How many modes does the fiber support at 1550 nm? [Jan./Feb.-2007, 10 Marks]

**Solution:**

i) Number of modes is given by,

$$M = \frac{1}{2} \left[ \frac{\pi a}{\lambda} \cdot NA \right]^2$$

$$1000 = \frac{1}{2} \left[ \frac{\pi a}{850 \times 10^{-9}} \times 0.20 \right]^2$$

$$2000 = 5.464 \times a^2$$

$$a = 60.49 \mu\text{m}$$

ii)

$$M = \frac{1}{2} \left[ \frac{\pi \times 60.49 \times 10^{-6}}{1320 \times 10^{-9}} \times 0.20 \right]^2$$

$$M = (14.39)^2 = 207.07$$

iii)

$$M = \frac{1}{2} \left[ \frac{\pi d}{\lambda} \cdot NA \right]^2$$

$$M = \frac{1}{2} \left[ \frac{\pi (50 \times 10^{-6})}{0.82 \times 10^{-6}} \times 0.243 \right]^2$$

**Example 1.7.3:** A multimode step index fiber with a core diameter of 80  $\mu\text{m}$  and a relative index difference of 1.5 % is operating at a wavelength of 0.85  $\mu\text{m}$ . If the core refractive index is 1.48, estimate the normalized frequency for the fiber and number of guided modes. [July/Aug.-2008, 6 Marks]

**Solution:**

**Given :** MM step index fiber,  $2a = 80 \mu\text{m}$   
 Core radius  $a = 40 \mu\text{m}$   
 Relative index difference,  $\Delta = 1.5\% = 0.015$   
 Wavelength,  $\lambda = 0.85 \mu\text{m}$   
 Core refractive index,  $n_1 = 1.48$   
 Normalized frequency,  $V = ?$   
 Number of modes,  $M = ?$   
 Numerical aperture

$$NA = n_1 (2\Delta)^{1/2}$$

Normalized frequency is given by,

$$V = \frac{2\pi a}{\lambda} NA$$

$$V = \frac{2\pi \times 40}{0.85} \times 0.2563$$

$$V = 75.78$$

Number of modes is given by,

$$M = \frac{1}{2} \left[ \frac{\pi \times 6.49 \times 10^{-6}}{1320 \times 10^{-7}} \times 0.20 \right]^2$$

$$M = 300.63$$

## 12. Mode Field Diameter and Spot Size

The mode field diameter is a fundamental parameter of a single mode fiber. This parameter is determined from mode field distributions of fundamental LP<sub>01</sub> mode.

- In step index and graded single mode fibers, the field amplitude distribution is approximated by Gaussian distribution. The mode field diameter (MFD) is the distance between opposite 1/e – 0.37 times the near field strength amplitude and power is 1/e<sup>2</sup> = 0.135 times.
- In single mode fiber for fundamental mode, on field amplitude distribution the mode field diameter is shown in fig. 1.8.1.

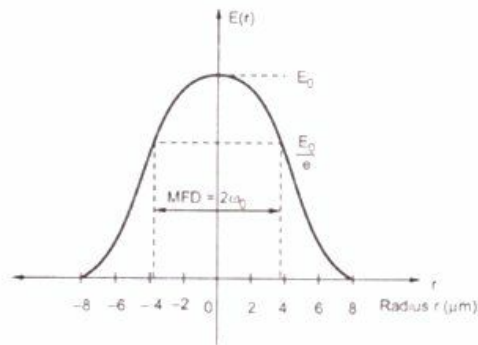

Fig. 1.8.1 Mode field diameter

The spot size  $\omega_0$  is given as –

$$\omega_0 = \frac{\text{MFD}}{2}$$

$$\text{MFD} = 2 \omega_0$$

The parameter takes into account the wavelength dependent field penetration into the cladding. Fig. 1.8.2 shows mode field diameters variation with  $\lambda$ .

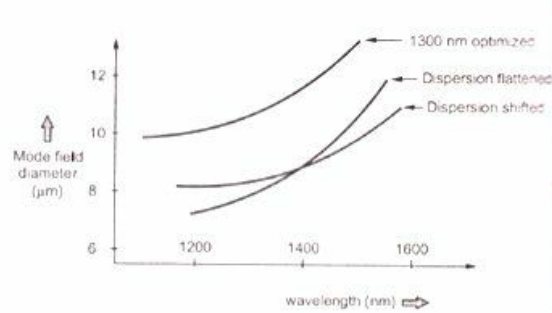

Fig. 1.8.2 Mode field diameter variations

## 13. Fiber Materials

### Requirements of Fiber Optic Material

1. The material must be transparent for efficient transmission of light.
2. It must be possible to draw long thin fibers from the material.
3. Fiber material must be compatible with the cladding material.

Glass and plastics fulfill these requirements.

- Most fiber consists of silica ( $\text{SiO}_2$ ) or silicate. Various types of high loss and low loss glass fibers are available to suit the requirements. Plastic fibers are not popular because of high attenuation they have better mechanical strength.

### Glass Fibers

- Glass is made by fusing mixtures of metal oxides having refractive index of 1.458 at 850 nm. For changing the refractive index different oxides such as  $\text{B}_2\text{O}_3$ ,  $\text{GeO}_2$  and  $\text{P}_2\text{O}_5$  are added as dopant. Fig. 1.8.3 shows variation of refractive index with doping concentration.

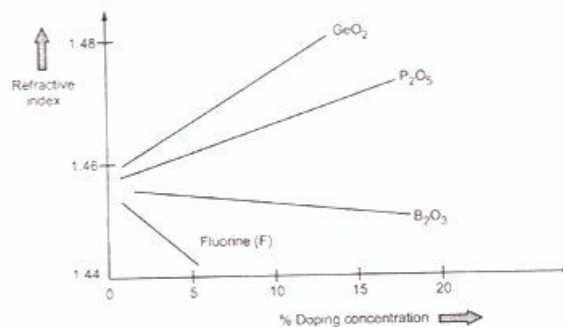

Fig. 1.8.3 Variation of refractive index with doping concentration

- The principal raw material for silica is sand and glass. The fiber composed of pure silica is called as silica glass. The desirable properties of silica glass are :-
  - Resistance to deformation even at high temperature.
  - Resistance to breakage from thermal shocks (low thermal expansion).



- Good chemical durability.
- Better transparency.
- Other types of glass fibers are
- Halide glass fibers.
- Active glass fibers
- Chalcogenide glass fibers
- Plastic optical fibers

### Fiber Fabrication Methods

- The vapor-phase oxidation process is popularly used for fabricating optical fibers. In this process vapors of metal halides such as  $\text{SiCl}_4$  and  $\text{GeCl}_4$  reactive with oxygen and forms powder of  $\text{SiO}_2$  particles. The  $\text{SiO}_2$  particles are collected on surface of bulk glass and then sintered to form a glass rod called Preform. The preforms are typically 10-25 mm diameter and 60-120 cm long from which fibers are drawn. A simple schematic of fiber drawing equipment

- The preform is feed to drawing furnace by precision feed mechanism. The preform is heated up in drawing furnace so that it becomes soft and fiber can be drawn easily.

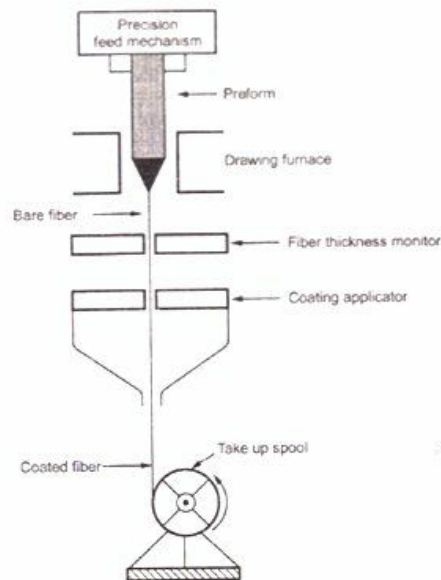

Fig. 1.8.4 Fiber drawing equipment

The fiber thickness monitoring decides the speed of take up spool. The fiber is then coated with elastic material to protect it from dust and water vapor.

## Outside Vapor-Phase Oxidation (OVPO)

- The OVPO process is a lateral deposition process. In OVPO process a layer of SiO<sub>2</sub> (Soot) is deposited from a burner on a rotating mandrel so as to make a preform.
- Fig. 1.8.5 shows this process.

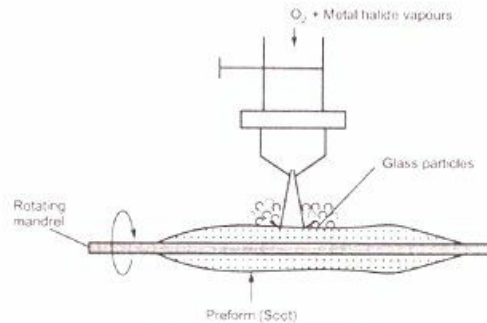

Fig. 1.8.5 OVPO process

- During the SiO<sub>2</sub> deposition O<sub>2</sub> and metal halide vapors can be controlled so the desired core-cladding diameters can be incorporated. The mandrel is removed when deposition process is completed; this preform is used for drawing thin filament of fibers in fiber drawing equipment.

## Vapor-Phase Axial Deposition (VAD)

- In VAD process, the SiO<sub>2</sub> particles are deposited axially. The rod is continuously rotated and moved upward to maintain symmetry of particle deposition.
- The advantages of VAD process are - Both step and graded index fibers are possible to fabricate in multimode and single mode.
- The performs does not have the central hole.
- The performs can be fabricated in continuous length.
- Clean environment can be maintained.

## Modified Chemical Vapor Deposition (MCVD)

- The MCVD process involves depositing ultra fine, vaporized raw materials into a premade silica tube. A hollow silica tube is heated to about 1500 oC and a mixture of oxygen and metal halide gases is passed through it. A chemical reaction occurs within the gas and glass '500t' is formed and deposited on the inner side of the tube. The soot that develops from this deposition is consolidated by heating. The tube is rotated while the heater is moved to and along the tube and the soot forms a thin layer of silica glass. The rotation and heater movement ensures that the layer is of constant thickness. The first layer that is deposited

forms the cladding and by changing the constituents of the incoming gas the refractive index can be modified to produce the core. Graded index fiber is produced by careful continuous control of the constituents.

- The temperature is now increased to about 1800 °C and the tube is collapsed to form a solid rod called a preform. The preform is about 25 mm in diameter and 1 meter in length. This will produce 25 km of fiber.

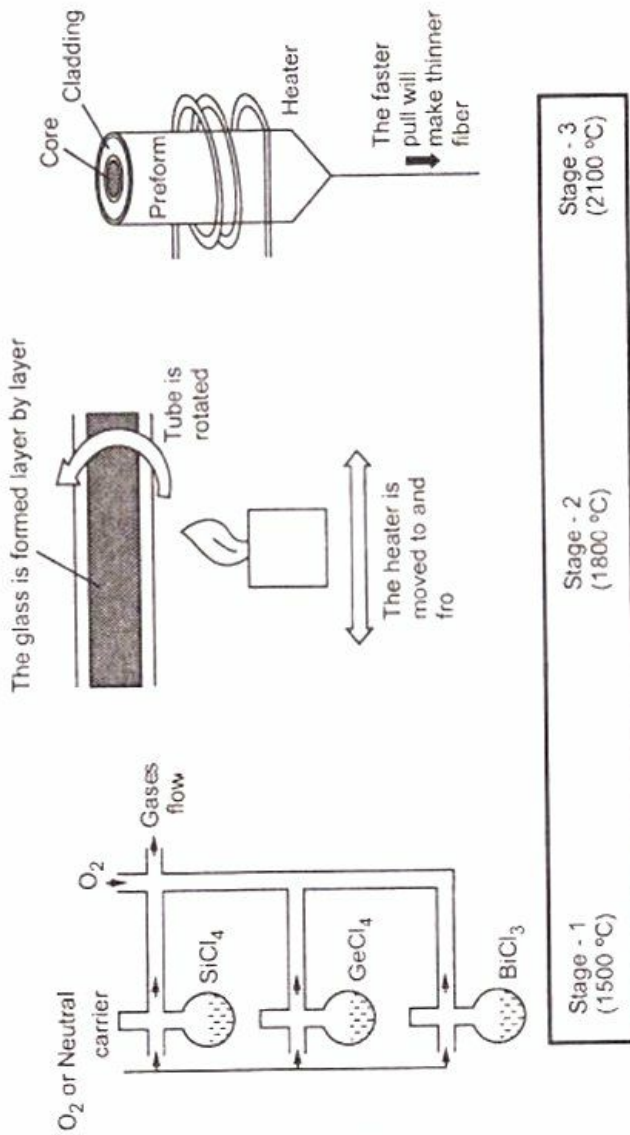

**Fig. 1.8.6 MCVD process**

- The preform is placed at a height called a pulling tower and its temperature is increased to about 2100 °C. To prevent contamination, the atmosphere is kept dry and clean.

The fiber is then pulled as a fine strand from the bottom, the core and cladding flowing towards the pulling point. Laser gauges continually monitor the thickness of the fiber and automatically adjust the pulling rate to maintain required thickness. After sufficient cooling the primary buffer is applied and the fiber is drummed.

- Fig. 1.8.6 (Refer Fig. 1.8.6 on previous page) shows the overall MCVD process.

### Plasma-Activated Chemical Vapor Deposition (PCVD)

- PCVD process is similar to MCVD process where the deposition occurs on silica tube at 1200 oC. It reduces mechanical stress on glass films. There is no soot formation and hence sintering is not required. Non-isothermal microwave plasma at low pressure initiates the chemical reaction.

### Double-Crucible Method

- Double-crucible method is a direct melt process. In double-crucible method two different glass rods for core and Cladding are used as feedstock for two concentric crucibles. The inner crucible is for core and outer crucible is for cladding. The fibers can be drawn from the orifices in the crucible. Fig. 1.8.7 shows double crucible method of fiber drawing.

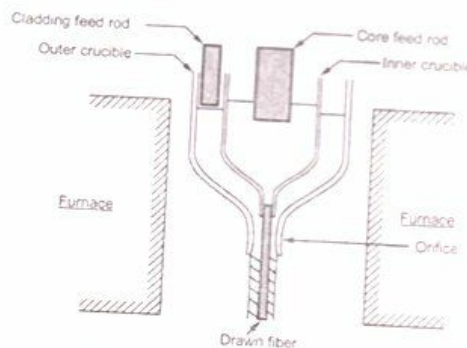

Fig. 1.8.7 Double-crucible method

Major advantage of double crucible method is that it is a continuous production process.

## 14. Fiber Optic Cables

The fiber optic cable is to be used under variety of situations such as underground, Outdoor poles or submerged under water. The structure of cable depends on the situation where it is to be used, but the basic cable design principles remain same.



- Mechanical property of cable is one of the important factor for using any specific cable. Maximum allowable axial load on cable decides the length of the cable be reliably installed.

- Also the fiber cables must be able to absorb energy from impact loads. The outer sheath must be designed to protect glass fibers from impact loads and from corrosive environmental elements.

### Fiber Arrangements

- Several arrangements of fiber cables are done to use it for different applications. The most basic form is two fiber cable designs. Fig. 1.10.1 shows basic two fiber cable design. It is also known as basic building block of fiber cable.

- For providing strength to the core several coatings of different materials are applied as shown in fig 1.10.1.

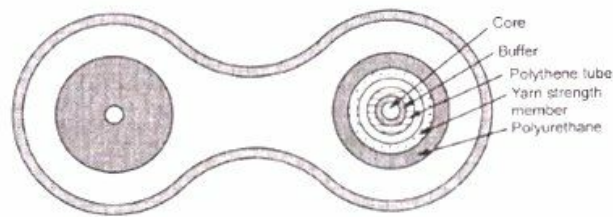

Fig. 1.10.1 Two fiber cable design

Multiple fiber cable can be combined together using similar techniques. Fig. 1.10.2 shows commonly used six fiber cables.

- The basic fiber building blocks are used to form large cable. These units are bound on a buffer material which acts as strength element along with insulated copper conductor. The fiber building blocks are surrounded by paper tape, PVC jacket, yarn and outer sheath.

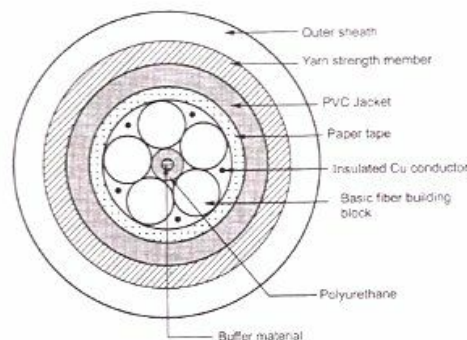

Fig. 1.10.2 Six fiber cable

## Fiber Optic Cable Ducts

- Number of cores is bundled in plastic ducts. To ease identification, individual fibers are colour coded Table 1.10.1 shows an example of the colour coding used by manufacturers

Fiber number	Colour
1	Blue
2	Orange
3	Green
4	Brown
5	Grey
6	White
7	Red
8	Black
9	Yellow
10	Violet
11	Pink or light blue
12	Turquoise or neutral

- If there are more than 12 fibers in a tube they are usually bundled together in quantities of 12 and held together with a coloured binding yarn.

## Plastic Fiber Optic Cables

- Fibers can also be manufactured from transparent plastic which offers advantages of larger diameter (1 mm), increased flexibility, can be cut using a hot razor blade, ease of termination. But because of high intrinsic loss use of plastic fibers is normally restricted to only few metres.
- Plastic optic fiber (POF) offers noise immunity and low cable weight and volume and is competitive with shielded copper wire making it suitable for industrial applications.

- Silica (glass) optical fiber has better transmission characteristics (Low loss) than POF. Also, silica fiber can tolerate higher temperature than plastic fiber. On the other hand, POF is more flexible, less prone to breakage, easier to fabricate and cost is low than glass fibers.

- Another advantage of glass/glass fiber is that very clean fracture surface can be obtained which ensures that fiber cladding inside the connector retains its optical characteristics right upto the end face to fiber. Whereas in plastic glass/plastic fiber some additional losses exist due to fracture zone of plastic which even after grinding and polishing still have microscope end face absorption areas. These advantages and disadvantages are summarized in Table 1.10.3.

Types of cladding	Advantages	Disadvantages
Glass glass fiber	<ul style="list-style-type: none"> <li>• Clean fracture surface.</li> <li>• Retention of optical characteristics.</li> </ul>	<ul style="list-style-type: none"> <li>• Less flexible than plastic fiber.</li> <li>• Prone to damage.</li> </ul>
Transparent plastic plastic fiber	<ul style="list-style-type: none"> <li>• Large diameter.</li> <li>• Increased flexibility.</li> <li>• Ease of termination.</li> </ul>	<ul style="list-style-type: none"> <li>• High intrinsic loss.</li> <li>• Additional losses at the fracture zone.</li> <li>• Limited distances of a few metres and to environments protected from temperature extremes.</li> </ul>

Table 1.10.3 Advantages and disadvantages of different fiber claddings

## Recommended Questions

1. State and explain the advantages and disadvantages of fiber optic communication systems?
2. State and explain in brief the principle of light propagation?
3. Define following terms with respect to optical laws –
  - A) Reflection
  - B) Refraction
  - C) Refractive index
  - D) Snell's law
  - E) Critical angle
  - F) Total internal reflection (TIR)
4. Explain the important conditions for TIR to exist in fiber.?

5. Derive an expression for maximum acceptance angle of a fiber?
6. Explain the acceptance cone of a fiber?
7. Define numerical aperture and state its significance also?
8. Explain the different types of rays in fiber optic?
9. Explain the following –?
  - A) Step index fiber
  - B) Graded index fiber
10. What is meant by mode of a fiber?
11. Write short notes on following –
  - A) Single mode step index fiber
  - B) Multimode step index fiber
  - C) Multimode graded index fiber.
12. Explain the fiber materials used in fabrication requirements?
13. In case of glass fibers how the refractive index can be varied?
14. Briefly explain following techniques of fabrication?
  - i) OVPO
  - ii) VAD
  - iii) MCVD
  - iv) PCVD



# Total Internal Reflection

When light travels from one medium to another it changes speed and is refracted. If the light rays are travelling from a less dense material to a dense medium they are refracted towards the normal and if they are travelling from a dense to less dense medium they are refracted away from the normal.

For total internal reflection to occur the light must travel from a dense medium to a less dense medium (e.g. glass to air or water to air).

As the angle of incidence increases so does the angle of refraction. When the angle of incidence reaches a value known as the **critical angle** the refracted rays travel along the surface of the medium or in other words are refracted to an angle of  $90^\circ$ . The critical angle for the angle of incidence in glass is  $42^\circ$ .

## 1. Angle of incidence less than the critical angle

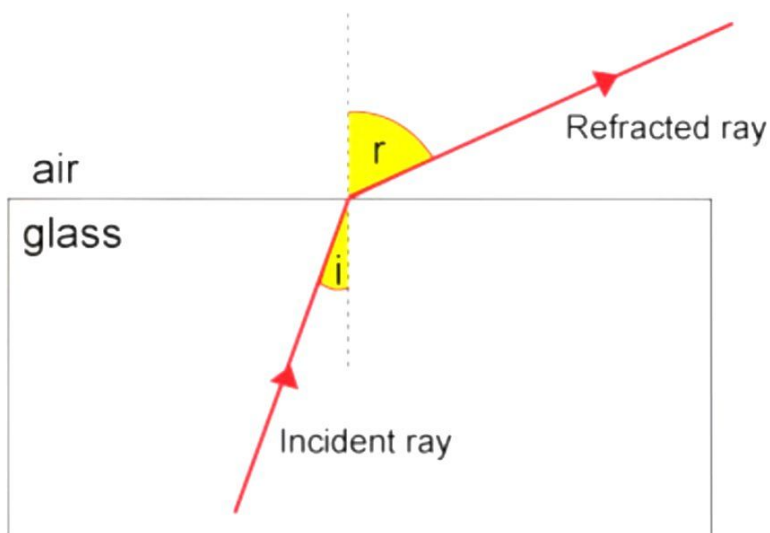

When the angle of incidence of the light ray leaving the glass is less than the critical angle, the light ray speeds up on leaving the glass and is refracted away from the normal.

## 2. Angle of incidence equal to the critical angle

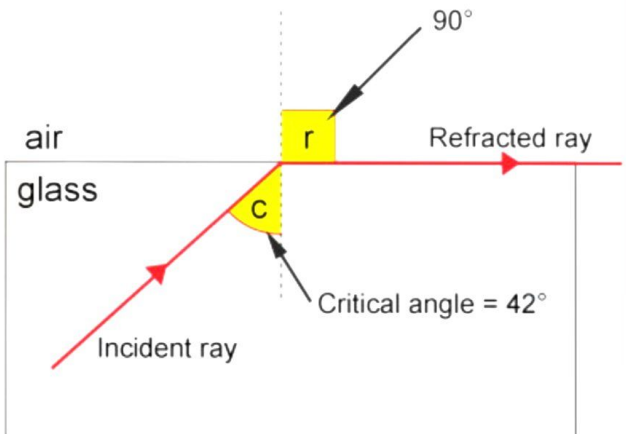

When the angle of incidence of the light ray reaches the critical angle ( $42^\circ$ ) the angle of refraction is  $90^\circ$ . The refracted ray travels along the surface of the denser medium in this case the glass.

## 3. Angle of incidence greater than the critical angle

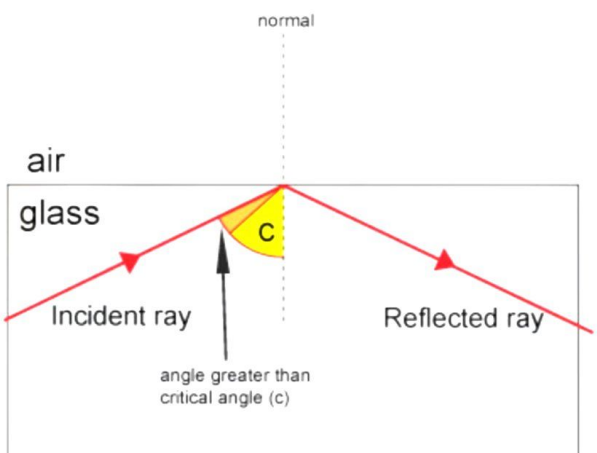

When the angle of incidence of the light ray is greater than the critical angle then no refraction takes place. Instead, all the light is reflected back into the denser material in this case the glass. This is called **total internal reflection**.